

Wi-Fi® Garage Door Openers

Belt Drive Models - 8550W 8550WL 8550WLB 8550WLB-267 8557W WLED WLED-267 85503 85503-267

Chain Drive Models - 8587W 8587WL 8580WLB

FOR RESIDENTIAL USE ONLY

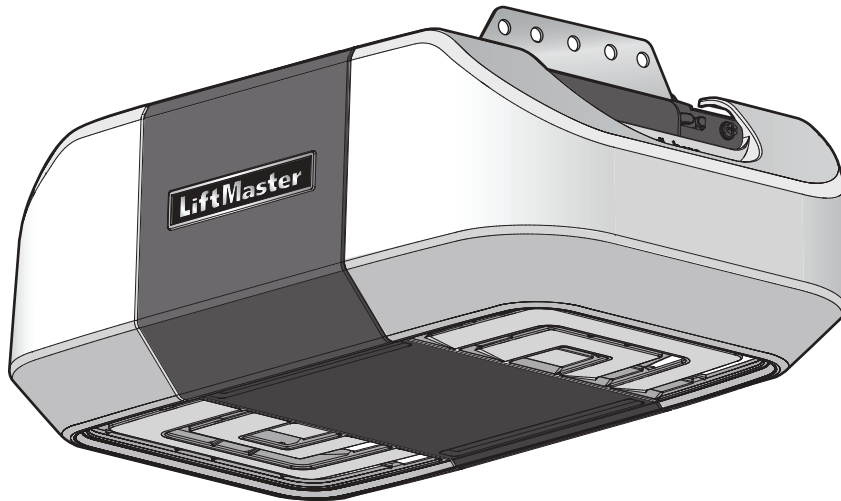

- Please read this manual and the safety materials carefully!
- The door **WILL NOT CLOSE** unless the Protector System® is connected and properly aligned.
- Periodic checks of the garage door opener are required to ensure safe operation.
- This garage door opener is **ONLY** compatible with myQ® and Security+ 2.0® accessories.
- **DO NOT** install on a one-piece door if using devices or features providing unattended close. Unattended devices and features are to be used **ONLY** with sectional doors.
- Attach warning labels to the location indicated on label.

Table of Contents

Preparation	3
Carton Inventory: Models 8550W, 8550WL, 8550WLB, 8550WLB-267, 8557WL, WLED, WLED-267, 85503 and 85503-267	6
Carton Inventory: Models 8587W, 8587WL, and 8580WLB	7
Assembly	8
Models 8550W, 8550WL, 8550WLB, 8550WLB-267, 8557W, WLED, WLED-267, 85503, and 85503-267	8
Models 8587W, 8587WL, and 8580WLB	10
Installation	12
Install the Door Control	20
Install the Protector System	22
Power	26
Adjustments	28
Battery Backup	31
Operation	33
Maintenance	41
Troubleshooting	42
Accessories	44
Warranty	45
Automatic Garage Door Opener Safety & Maintenance Guide	46
Repair Parts	48
Models 8550W, 8550WL, 8550WLB, 8550WLB-267, 8557W, 85503 and 85503-267	48
Models WLED and WLED-267	51
Models 8587W, 8587WL, and 8580WLB	53

Preparation

myQ® Serial Number

Write down the following information for future reference:

myQ® Serial Number:

Product S/N:

Date of Purchase:

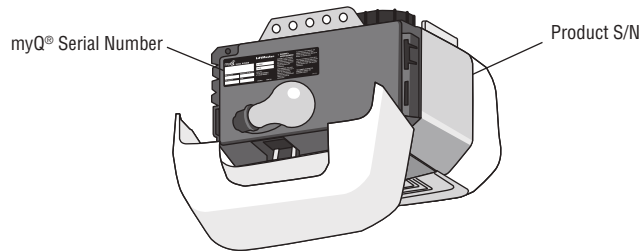
 / 

Safety Symbol and Signal Word Review

This garage door opener has been designed and tested to offer safe service provided it is installed, operated, maintained and tested in strict accordance with the instructions and warnings contained in this manual.

When you see these Safety Symbols and Signal Words on the following pages, they will alert you to the possibility of **serious injury or death** if you do not comply with the warnings that accompany them. The hazard may come from something mechanical or from electric shock. Read the warnings carefully.

 **WARNING**

Mechanical

 **WARNING**

Electrical

When you see this Signal Word on the following pages, it will alert you to the possibility of damage to your garage door and/or the garage door opener if you do not comply with the cautionary statements that accompany it. Read them carefully.

 **CAUTION**



WARNING: This product can expose you to chemicals including lead, which are known to the State of California to cause cancer or birth defects or other reproductive harm. For more information go to www.P65Warnings.ca.gov

Unattended Operation

The Timer-to-Close (TTC) feature, the myQ® App, and myQ® Garage Door and Gate Monitor are examples of unattended close and are to be used **ONLY** with sectional doors. Any device or feature that allows the door to close without being in the line of sight of the door is considered unattended close. The Timer-to-Close (TTC) feature, the myQ® App, and any other myQ® devices are to be used **ONLY** with sectional doors.

Preparation

Before You Connect with Your Smartphone

Monitor and control your garage door from anywhere using the myQ® App.

You will need:

- Wi-Fi enabled smartphone, tablet or laptop
- Broadband Internet Connection
- Wi-Fi signal in the garage (**2.4 GHz, 802.11b/g/n required**)
- Password for your home network (router's main account, not guest network)

TEST THE WI-FI SIGNAL STRENGTH

Make sure your mobile device is connected to your Wi-Fi network. Hold your mobile device in the place where your garage door opener will be installed and check the Wi-Fi signal strength.



Check Signal Strength. If you see:



Wi-Fi signal is strong.
The garage door opener will connect to your Wi-Fi network.



Wi-Fi signal is weak.
The garage door opener may connect to your Wi-Fi network. If not, try one of the options below to improve the Wi-Fi signal:



No Wi-Fi signal.
The garage door opener will not be able to connect to your Wi-Fi network. Try one of the options below to improve the Wi-Fi signal:

- Move your router closer to the garage door opener to minimize interference from walls and other objects
- Buy a Wi-Fi range extender

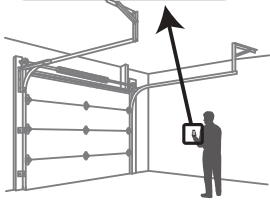

For compatible router specifications and help, visit support.chamberlaingroup.com.

See page 35 to connect the garage door opener to a mobile device.

See page 35 to setup the camera (models 85503 and 85503-267 only).

Check the Door

WARNING

To prevent possible **SERIOUS INJURY** or **DEATH**:

- ALWAYS call a trained door systems technician if garage door binds, sticks, or is out of balance. An unbalanced garage door may NOT reverse when required.
- NEVER try to loosen, move or adjust garage door, door springs, cables, pulleys, brackets or their hardware, ALL of which are under **EXTREME** tension.
- Disable ALL locks and remove ALL ropes connected to garage door BEFORE installation and operating garage door opener to avoid entanglement.
- DO NOT install on a one-piece door if using devices or features providing unattended close. Unattended devices and features are to be used **ONLY** with sectional doors.

CAUTION

To prevent damage to garage door and opener:

- ALWAYS disable locks BEFORE installing and operating the opener.
- **ONLY** operate garage door opener at 120V, 60 Hz to avoid malfunction and damage.

Before you begin:

1. Disable locks and remove any ropes connected to the garage door.
2. Lift the door halfway up. Release the door. If balanced, it should stay in place, supported entirely by its springs.
3. Raise and lower the door to check for binding or sticking. If your door binds, sticks, or is out of balance, call a trained door systems technician.
4. Check the seal on the bottom of the door. Any gap between the floor and the bottom of the door must not exceed 1/4" (6 mm). Otherwise, the safety reversal system may not work properly.
5. The opener should be installed above the center of the door. If there is a torsion spring or center bearing plate in the way of the header bracket, it may be installed within 4 feet (1.2 m) to the left or right of the door center. See page 13.

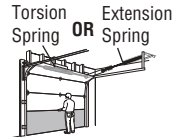

Preparation

Tools Needed

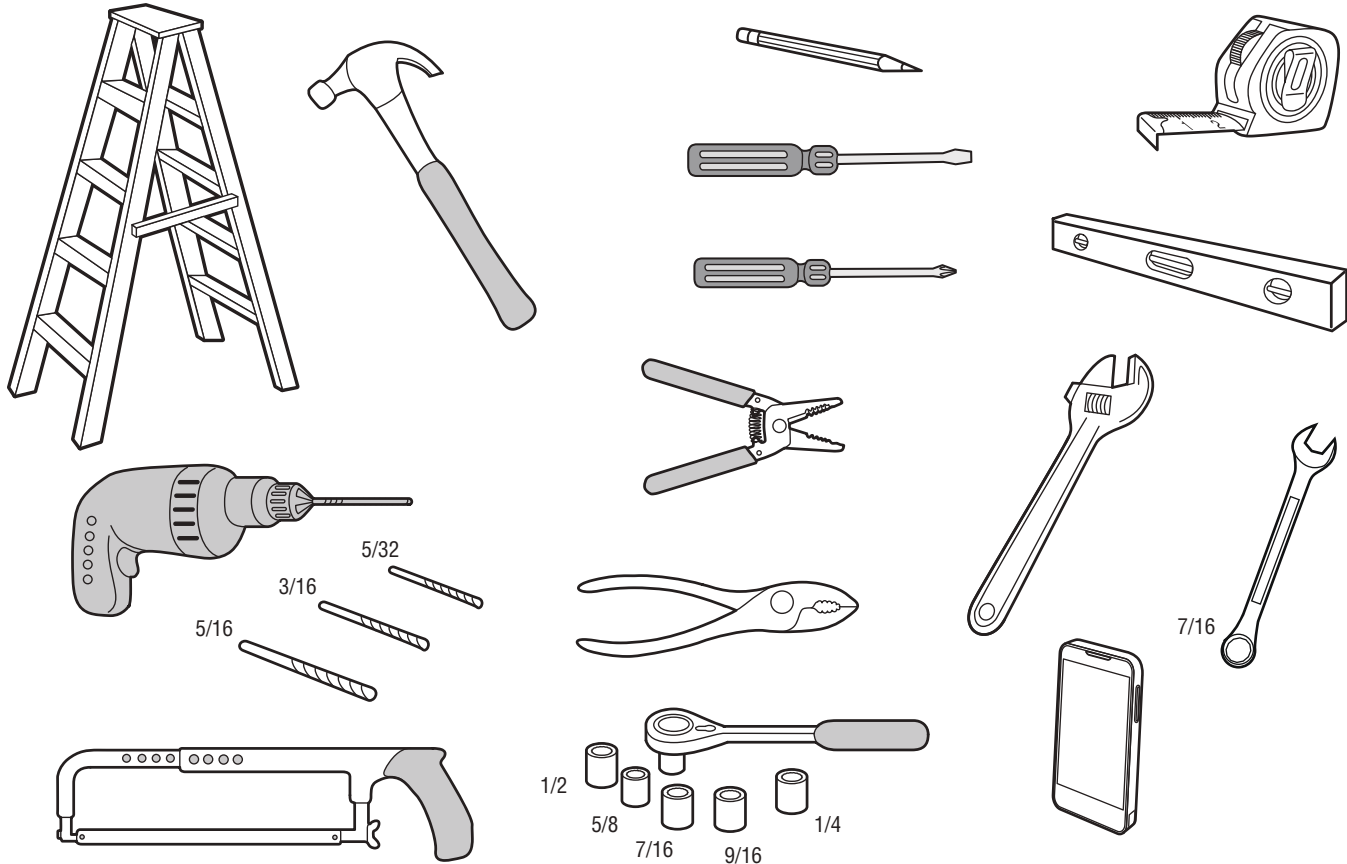

Preparation

Carton Inventory: Models 8550W, 8550WL, 8550WLB, 8550WLB-267, 8557WL, WLED, WLED-267, 85503 and 85503-267

Accessories will vary depending on the garage door opener model purchased. Depending on your specific model, other accessories may be included with your garage door opener. The instructions for these accessories will be attached to the accessory and are not included in this manual. **The images throughout this manual are for reference and your product may look different.**

- A. Header bracket
- B. Pulley and bracket
- C. Door bracket
- D. Curved door arm
- E. Straight door arm
- F. Trolley
- G. Emergency release rope and handle
- H. Rail
- I. Garage door opener
- J. Sprocket cover with hex screws
- K. Belt
- L. Door control
- M. White and red/white wire
- N. The Protector System
Safety reversing sensors with white and white/black wire attached: Sending sensor (1), receiving sensor (1), and safety sensor brackets (2)
- O. Safety labels and literature
- P. Rail grease
- Q. Battery (If applicable)

SECURITY+ 2.0 ACCESSORIES

893MAX

3- Button Remote Control



880LMW

Smart Control Panel®



INSTALLATION

- Hex Bolt 5/16"-18 x 7/8" (4)
- Lag Screw 5/16"-9 x 1-5/8" (2)
- Clevis Pin 5/16" x 2-3/4" (1)
- Clevis Pin 5/16" x 1-1/4" (1)
- Clevis Pin 5/16" x 1" (1)
- Nut 5/16"-18 (4)

- Lock Washer 5/16" (4)
- Self-Threading Screw 1/4"-14 x 5/8" (2)
- Ring Fastener (3)
- Carriage Bolt 1/4"-20 x 1/2" (2)
- Wing Nut 1/4"-20 (2)

DOOR CONTROL HARDWARE

- Screw 6AB x 1" (2)
- Screw 6-32 x 1" (2)
- Drywall Anchors (2)

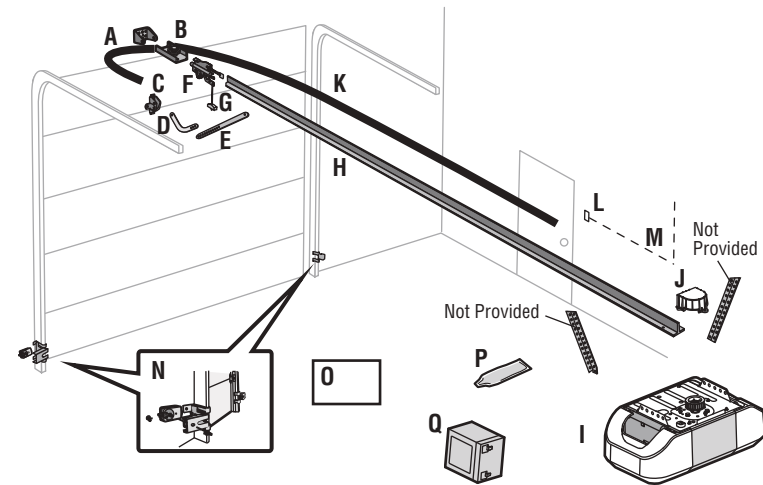

Preparation

Carton Inventory: Models 8587W, 8587WL, and 8580WLB

Accessories will vary depending on the garage door opener model purchased. Depending on your specific model, other accessories may be included with your garage door opener. The instructions for these accessories will be attached to the accessory and are not included in this manual. **The images throughout this manual are for reference and your product may look different.**

Garage Door Opener Assembly

- A. Header bracket
- B. Pulley and bracket
- C. Door bracket
- D. Curved door arm
- E. Straight door arm
- F. Trolley
- G. Emergency release rope and handle
- H. Rail
- I. Garage door opener
- J. Chain spreader
- K. Chassis support bracket
- L. Chain
- M. Door control
- N. White and red/white wire
- O. The Protector System
Safety reversing sensors with white and white/black wire attached: Sending sensor (1), receiving sensor (1), and safety sensor brackets (2)
- P. Safety labels and literature
- Q. Rail grease

SECURITY+ 2.0 ACCESSORIES

893MAX
3- Button Remote Control



880LMW
Smart Control Panel®



Hardware

Assembly

Chassis Support Bracket Hardware

- Screw #8-32 x 3/8" (2)
- Hex Bolts 1/4"-20 x 5/8" (2)
- Lock Washers (2)
- Washed Bolt 5/16"-18 x 1/2" (2)

Installation

- Hex Bolt 5/16"-18 x 7/8" (4)
- Lag Screw 5/16"-9 x 1-5/8" (2)
- Lag Screw 5/16"-18 x 1-5/8" (2)
- Clevis Pin 5/16" x 2-3/4" (1)
- Clevis Pin 5/16" x 1-1/4" (1)
- Clevis Pin 5/16" x 1" (1)
- Nut 5/16"-18 (4)
- Lock Washer 5/16"-16 (4)

Door Control Hardware

- Screw 6AB x 1" (2)
- Screw 6-32 x 1" (2)

Chain Spreader Hardware

- Screw #8-32 x 3/8" (2)

Rail Hardware

Washed Bolts and Lock Washer (mounted in the top of the garage door opener)

Self-Threading Screw 1/4"-14 x 5/8" (2)

Ring Fastener (3)

Carriage Bolt 1/4"-20 x 1/2" (2)

Wing Nut 1/4"-20 (2)

Hex Bolt 1/4"-20 x 5/8" (2)

Lock Nut 1/4"-20 (2)

Lag Screw 1/4" x 1-1/2" (4)

Drywall Anchors (2)

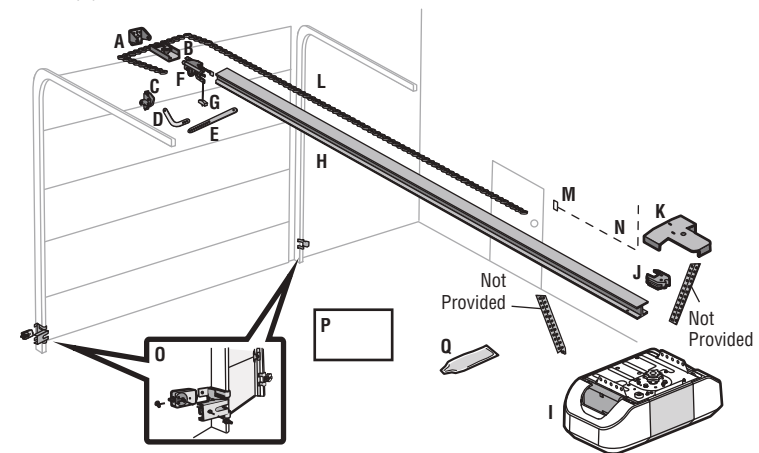

Assembly

1 Attach the Rail to the Garage Door Opener

MODELS 8550W, 8550WL, 8550WLB, 8550WLB-267, 8557W, WLED, WLED-267, 85503, AND 85503-267

WARNING

To avoid possible SERIOUS INJURY to finger from moving garage door opener:

- ALWAYS keep hand clear of sprocket while operating opener.
- Securely attach sprocket cover BEFORE operating.

CAUTION

To avoid SERIOUS damage to garage door opener, use ONLY those bolts/fasteners mounted in the top of the opener.

NOTE: ONLY use the bolts removed from the garage door opener. Place the garage door opener on the packing material to prevent scratching.

1. **Models 8550W, 8550WL, 8550WLB, 8550WLB-267, WLED, WLED-267, 85503, and 85503-267:** Remove the two bolts from the top of the garage door opener.
Model 8557W: Remove bolt and lock nut from the top of the garage door opener.
2. Align the rail and the styrofoam over the sprocket. Cut the tape from the rail, belt, and styrofoam.
3. **Models 8550W, 8550WL, 8550WLB, 8550WLB-267, WLED, WLED-267, 85503, and 85503-267:** Fasten the rail with the previously removed bolts.
Model 8557W: Fasten the rail with the previously removed washered bolt and lock nut.
4. Position the belt around the garage door opener sprocket.
5. Attach the sprocket cover over the garage door opener sprocket and attach with hex screws.
6. Align the rail and the styrofoam over the sprocket. Cut the tape from the rail, belt, and styrofoam.
7. Position the belt around the garage door opener sprocket.
8. Attach the sprocket cover over the garage door opener sprocket and attach with hex screws.

HARDWARE

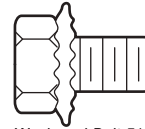

Washer Bolt 5/16"-18x1/2"
(Mounted in the garage door opener)
Models 8550W, 8550WL, 8550WLB,
8550WLB-267, WLED, and WLED-267 (2)
Model 8557W (1)



Lock Nut
(Mounted in the
garage door opener)
Model 8557W (1)



Hex Screw
#8x3/8"
(Packed with the
sprocket cover)

Models 8550W, 8550WL, 8550WLB, 8550WLB-267, WLED, and WLED-267

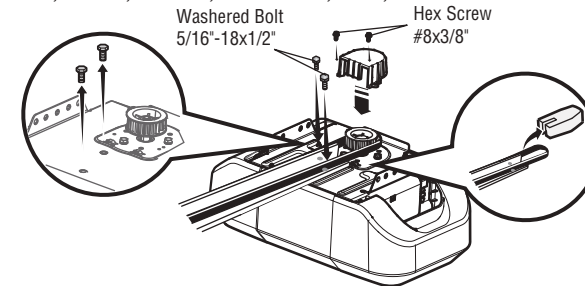

Model 8557W

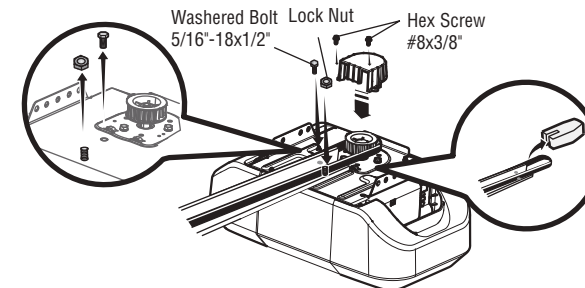

Assembly

2 Tighten the Belt

MODELS 8550W, 8550WL, 8550WLB, 8550WLB-267, 8557W, WLED, WLED-267, 85503, AND 85503-267

1. By hand, thread the spring trolley nut on the threaded shaft until it is finger tight against the trolley. Do not use any tools.
2. Insert a flathead screwdriver tip into one of the nut ring slots and brace it firmly against the trolley.
3. Tighten the spring trolley nut with an adjustable wrench or a 7/16" open end wrench about a quarter turn until the spring releases and snaps the nut ring against the trolley. This sets the spring to optimum belt tension.

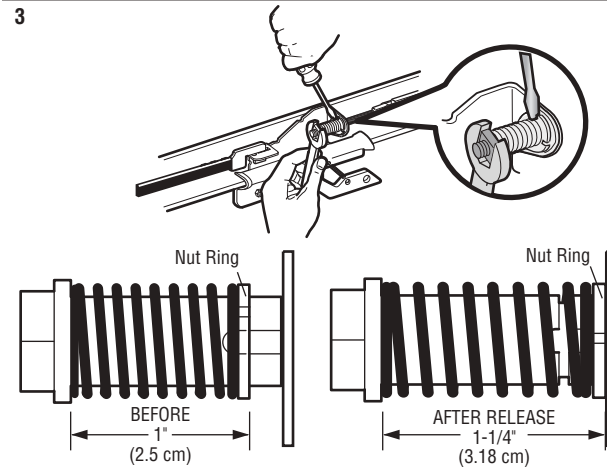
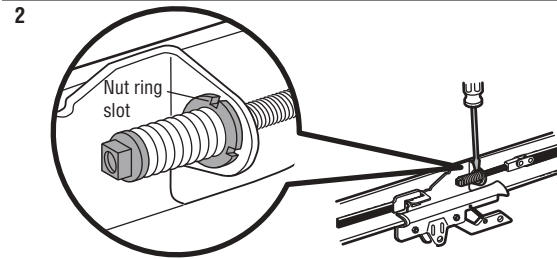
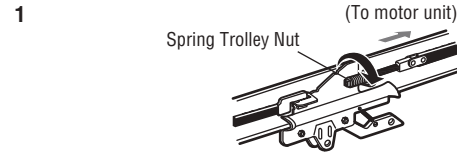

Assembly

1 Attach the Rail to the Garage Door Opener

MODELS 8587W, 8587WL, AND 8580WLB

CAUTION

To avoid SERIOUS damage to garage door opener, use ONLY those bolts/fasteners mounted in the top of the opener.

NOTE: ONLY use the bolts removed from the garage door opener. Place the garage door opener on the packing material to prevent scratching.

1. Remove bolt and lock nut from the top of the garage door opener.
2. Align the rail and the styrofoam over the sprocket. Cut the tape from the rail, chain, and styrofoam.
3. Fasten the rail with the previously removed washered bolt and lock nut.
4. Position the chain around the garage door opener sprocket.
5. Attach the chain spreader to the garage door opener with screws.
6. **Models 8587W and 8587WL Only:** Guide the chain around the selected groove in the chain spreader, to engage either the 8-tooth or 6-tooth sprocket.

NOTE: The 6-tooth sprocket is for use with Carriage House Doors and the 8-tooth sprocket is for use with regular doors.

HARDWARE

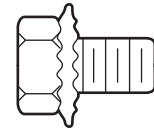

Washed Bolt
5/16"-18x1/2"
(Mounted in the garage
door opener)



Lock Nut
(Mounted in the
garage door opener)

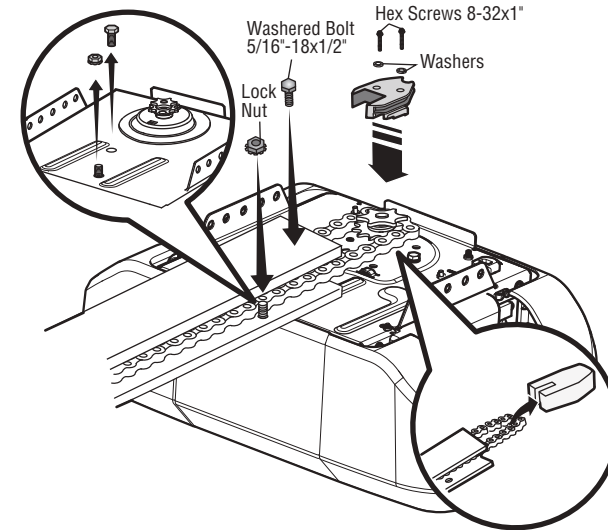

Models 8587W and 8587WLB only

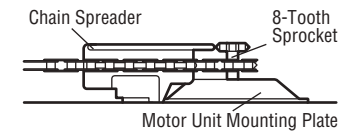
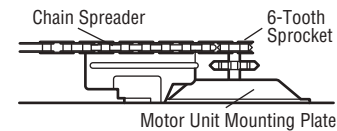

Assembly

2 Attach the Chassis Support Bracket

MODELS 8587W, 8587WL, AND 8580WLB

WARNING

To avoid possible SERIOUS INJURY to finger from moving garage door opener:

- ALWAYS keep hand clear of sprocket while operating opener.
- Securely attach sprocket cover BEFORE operating.

1. Position the chassis support bracket on the unit.
2. Attach the bracket to the rail with 1/4"-20 x 5/8" hex bolts and lock washers. **Do not overtighten.**
3. Attach the bracket to the opener by inserting a 5/16"-18 x 1/2" washered screw through a hole in each side flange and a matching hole in the bracket. Complete the connection by inserting the #8-32 x 3/8" screw through the back flange and the hole in rail support.

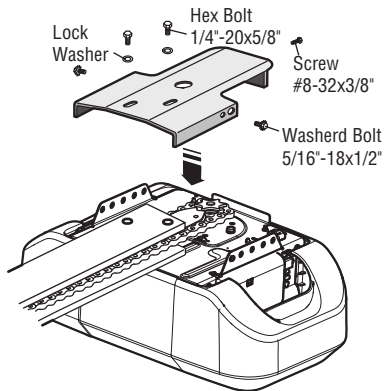

3 Tighten the Chain

1. Loosen the inner nut and lock washer on the trolley threaded shaft.
2. Tighten the outer nut until the chain is 1/2" above the base of the rail at the midpoint of the rail.
3. Re-tighten the inner nut.

Slack in the chain is normal when the door is closed. No readjustment is necessary.

Model 8580WLB Only: If the tension is not correct with a 7' rail installed, remove two links from the chain to set the correct tension.

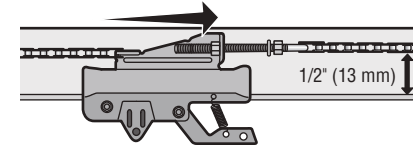

Installation

IMPORTANT INSTALLATION INSTRUCTIONS

WARNING

To reduce the risk of SEVERE INJURY or DEATH:

1. READ AND FOLLOW ALL INSTALLATION WARNINGS AND INSTRUCTIONS.
2. Install garage door opener ONLY on properly balanced and lubricated garage door. An improperly balanced door may NOT reverse when required and could result in SEVERE INJURY or DEATH.
3. ALL repairs to cables, spring assemblies and other hardware MUST be made by a trained door systems technician BEFORE installing opener.
4. Disable ALL locks and remove ALL ropes connected to garage door BEFORE installing opener to avoid entanglement.
5. Where possible, install the door opener 7 feet (2.13 m) or more above the floor.
6. Mount the emergency release within reach, but at least 6 feet (1.83 m) above the floor and avoiding contact with vehicles to avoid accidental release.
7. NEVER connect garage door opener to power source until instructed to do so.
8. NEVER wear watches, rings or loose clothing while installing or servicing opener. They could be caught in garage door or opener mechanisms.
9. Install wall-mounted garage door control:
 - within sight of the garage door.
 - out of reach of small children at a minimum height of 5 feet (1.5 m) above floors, landings, steps or any other adjacent walking surface.
 - away from ALL moving parts of the door.
10. Place entrapment warning label on wall next to garage door control in a prominent location.
11. Place emergency release/safety reverse test label in plain view on inside of garage door.
12. Upon completion of installation, test safety reversal system. Door MUST reverse on contact with a 1-1/2" (3.8 cm) high object (or a 2x4 laid flat) on the floor.
13. DO NOT install on a one-piece door if using devices or features providing unattended close. Unattended devices and features are to be used ONLY with sectional doors.

Installation

1 Determine the Header Bracket Location

WARNING

To prevent possible **SERIOUS INJURY** or **DEATH**:

- Header bracket **MUST** be **RIGIDLY** fastened to structural support on header wall or ceiling, otherwise garage door might **NOT** reverse when required. **DO NOT** install header bracket over drywall.
- Concrete anchors **MUST** be used if mounting header bracket or 2x4 into masonry.
- **NEVER** try to loosen, move or adjust garage door, springs, cables, pulleys, brackets, or their hardware, **ALL** of which are under **EXTREME** tension.
- **ALWAYS** call a trained door systems technician if garage door binds, sticks, or is out of balance. An unbalanced garage door might **NOT** reverse when required.
- **DO NOT** enable the Timer-to-Close functionality if operating either one-piece or swinging garage doors. To be enabled **ONLY** when operating a sectional door.

Close the door and mark the inside vertical centerline of the garage door.

Extend the line onto the header wall above the door. You can fasten the header bracket within 4 feet (1.22 m) of the left or right of the door center only if a torsion spring or center bearing plate is in the way; or you can attach it to the ceiling when clearance is minimal. (It may be mounted on the wall upside down if necessary, to gain approximately 1/2" (1 cm). If you need to install the header bracket on a 2x4 (on wall or ceiling), use lag screws (not provided) to securely fasten the 2x4 to structural supports.

Open your door to the highest point of travel as shown. Draw an intersecting horizontal line on the header wall 2" (5 cm) above the high point. This height will provide travel clearance for the top edge of the door.

NOTE: If the total number of inches exceeds the height available in your garage, use the maximum height possible, or refer to page 14 for ceiling installation.

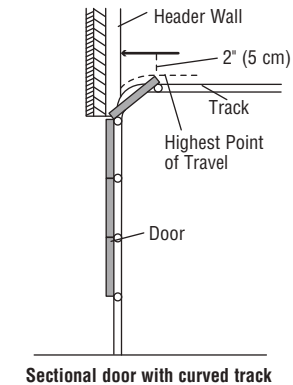
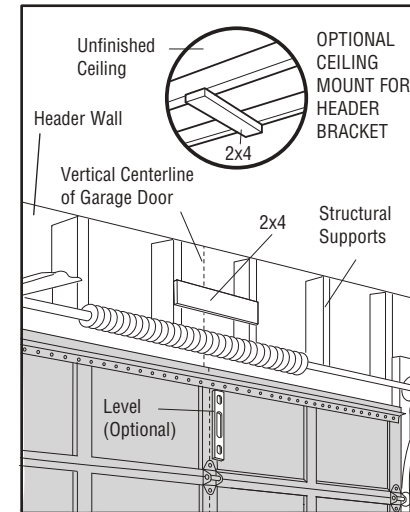

Installation

2 Install the Header Bracket

You can attach the header bracket either to the wall above the garage door, or to the ceiling. Follow the instructions which will work best for your particular requirements. **Do not install the header bracket over drywall. If installing into masonry, use concrete anchors (not provided).**

HARDWARE

Lag Screw 5/16"-9x1-5/8"

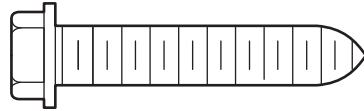

OPTION A - WALL INSTALLATION

1. Center the bracket on the vertical centerline with the bottom edge of the bracket on the horizontal line as shown (with the arrow pointing toward the ceiling).
2. Mark the vertical set of bracket holes (do not use the holes designated for ceiling mount). Drill 3/16" pilot holes and fasten the bracket securely to a structural support with lag screws.

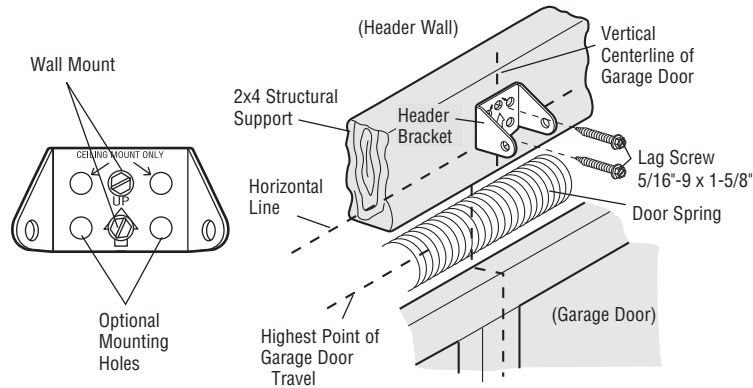

OPTION B - CEILING INSTALLATION

1. Extend the vertical centerline onto the ceiling as shown.
2. Center the bracket on the vertical mark, no more than 6" (15 cm) from the wall. Make sure the arrow is pointing toward the wall. The bracket can be mounted flush against the ceiling when clearance is minimal.
3. Mark the side holes. Drill 3/16" pilot holes and fasten bracket securely to a structural support with the hardware provided.

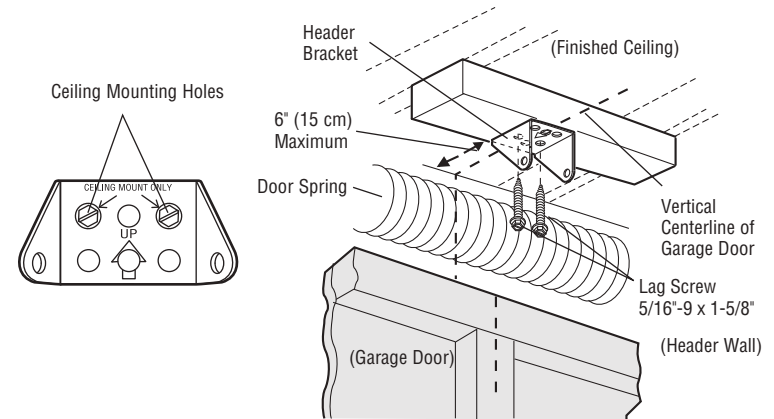

Installation

3 Attach the Rail to the Header Bracket

1. Align the rail with the header bracket. Insert the clevis pin through the holes in the header bracket and rail. Secure with the ring fastener.

NOTE: Use the packing material as a protective base for the garage door opener.

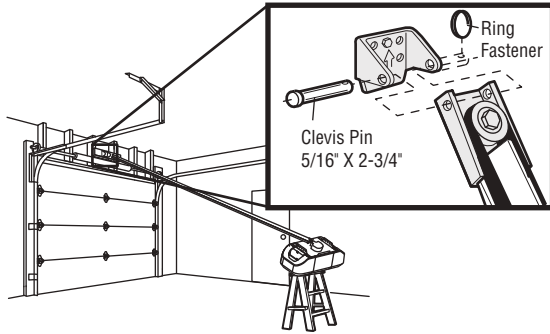
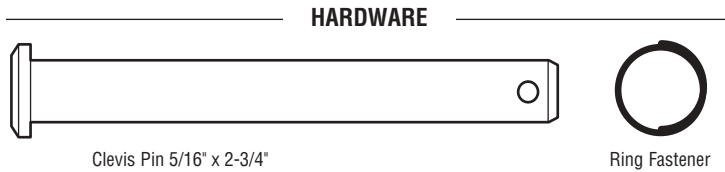

4 Position the Garage Door Opener

CAUTION

To prevent damage to garage door, rest garage door opener rail on 2x4 placed on top section of door.

1. Remove the packing material and lift the garage door opener onto a ladder.
 2. Fully open the door and place a 2x4 (laid flat) under the rail.
- A 2x4 is ideal for setting the distance between the rail and the door. If the ladder is not tall enough you will need help at this point. If the door hits the trolley when it is raised, pull the trolley release arm down to disconnect the inner and outer trolley. Slide the outer trolley toward the garage door opener. The trolley can remain disconnected until instructed.

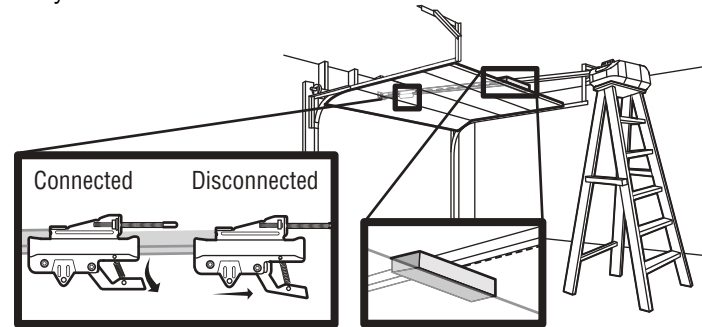

Installation

5 Hang the Garage Door Opener

WARNING

To avoid possible **SERIOUS INJURY** from a falling garage door opener, fasten it **SECURELY** to structural supports of the garage. Concrete anchors **MUST** be used if installing **ANY** brackets into masonry.

Hanging your garage door opener will vary depending on your garage. Two representative installations are shown. Yours may be different. Hanging brackets should be angled (Figure 1) to provide rigid support. On finished ceilings (Figure 2), attach a sturdy metal bracket to structural supports before installing the opener. This bracket and fastening hardware are not provided.

1. Measure the distance from each side of the motor unit to the structural support.
2. Cut both pieces of the hanging bracket to required lengths.
3. Drill 3/16" pilot holes in the structural supports.
4. Attach one end of each bracket to a support with 5/16"-18 x 1-7/8" lag screws (not provided).
5. Fasten the opener to the hanging brackets with 5/16"-18 x 7/8" hex bolts, lock washers and nuts.
6. Check to make sure the rail is centered over the door (or in line with the header bracket if the bracket is not centered above the door).
7. Remove the 2x4. Operate the door manually. If the door hits the rail, raise the header bracket.

NOTE: *DO NOT* connect power to opener at this time.

HARDWARE



Lock Washer 5/16"

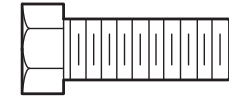

Hex Bolt 5/16"- 18x7/8"



Nut 5/16"-18

FIGURE 1

Unfinished Ceiling

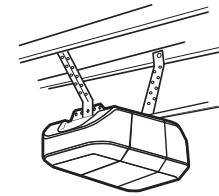

FIGURE 2

Finished Ceiling

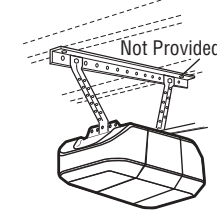
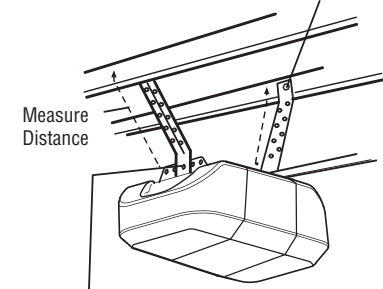

FIGURE 3

(Not Provided)
Lag Screws
5/16"- 18x1-7/8"



Hex Bolt 5/16"- 18x7/8", Lock Washer 5/16", Nut 5/16"-18

Installation

6 Install the Light Bulbs

MODELS 8550W, 8550WL, 8550WLB, 8550WLB-267, 8557W, 8587W, 8587WL, 8580WLB, 85503, AND 85503-267

CAUTION

To prevent possible OVERHEATING of the end panel or light socket:

- Use ONLY A19 incandescent (100W maximum) or compact fluorescent (26W maximum) light bulbs.
- DO NOT use incandescent bulbs larger than 100W.
- DO NOT use compact fluorescent light bulbs larger than 26W (100W equivalent).
- DO NOT use halogen bulbs.
- DO NOT use short neck or specialty light bulbs.

1. Pull on the top center of the light lens and rotate the light lens down.
2. Insert an A19 incandescent (100W maximum) or compact fluorescent (26W, 100W equivalent) light bulb into the light socket.

NOTE: DO NOT use halogen, short neck, or specialty light bulbs as these may overheat the end panel or light socket. DO NOT use LED bulbs as they may reduce the range or performance of your remote control(s).

3. Rotate the lens up to close.

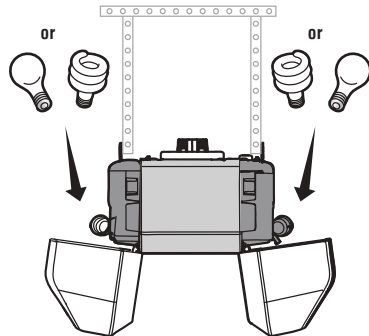

7 Attach the Emergency Release Rope and Handle

WARNING

To prevent possible SERIOUS INJURY or DEATH from a falling garage door:

- If possible, use emergency release handle to disengage trolley ONLY when garage door is CLOSED. Weak or broken springs or unbalanced door could result in an open door falling rapidly and/or unexpectedly.
- NEVER use emergency release handle unless garage doorway is clear of persons and obstructions.
- NEVER use handle to pull door open or closed. If rope knot becomes untied, you could fall.

1. Insert one end of the emergency release rope through the handle. Make sure that "NOTICE" is right side up. Secure with an overhand knot at least 1" (2.5 cm) from the end of the rope to prevent slipping.
2. Insert the other end of the emergency release rope through the hole in the trolley release arm. Mount the emergency release within reach, but at least 6 feet (1.83 m) above floor, avoiding contact with vehicles to prevent accidental release and secure with an overhand knot.

NOTE: If it is necessary to cut the emergency release rope, seal the cut end with a match or lighter to prevent unraveling. Ensure the emergency release rope and handle are above the top of all vehicles to avoid entanglement.

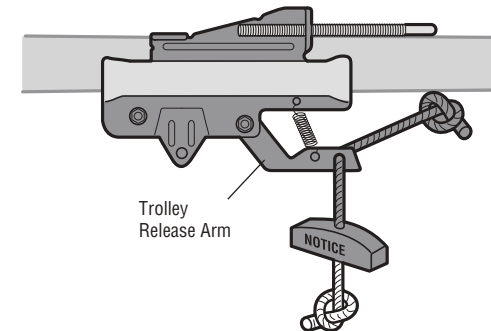

Installation

8 Install the Door Bracket

⚠ CAUTION

Fiberglass, aluminum or lightweight steel garage doors **WILL REQUIRE** reinforcement BEFORE installation of door bracket. Contact the garage door manufacturer or installing dealer for opener reinforcement instructions or reinforcement kit. Failure to reinforce the top section as required according to the door manufacturer may void the door warranty.

A horizontal and vertical reinforcement is needed for lightweight garage doors (fiberglass, aluminum, steel, doors with glass panel, etc.) (not provided). A horizontal reinforcement brace should be long enough to be secured to two or three vertical supports. A vertical reinforcement brace should cover the height of the top panel. Contact the garage door manufacturer or installing dealer for opener reinforcement instructions or reinforcement kit.

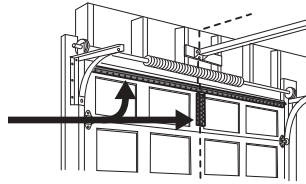

NOTE: Many door reinforcement kits provide for direct attachment of the clevis pin and door arm. In this case you will not need the door bracket; proceed to the next step.

SECTIONAL DOORS

1. Center the door bracket on the previously marked vertical centerline used for the header bracket installation. Note correct UP placement, as stamped inside the bracket.
2. Position the top edge of the bracket 2"-4" (5-10 cm) below the top edge of the door, OR directly below any structural support across the top of the door.
3. Mark, drill holes and install as follows, depending on your door's construction:

Metal or light weight doors using a vertical angle iron brace between the door panel support and the door bracket:

- Drill 3/16" fastening holes. Secure the door bracket using the two self threading screws. (Figure 1)
- Alternately, use two 5/16"-18x2" bolts, lock washers and nuts (not provided). (Figure 2)

Metal, insulated or light weight factory reinforced doors:

- Drill 3/16" fastening holes. Secure the door bracket using the self-threading screws. (Figure 3)

Wood Doors:

- Use top and bottom or side to side door bracket holes. Drill 5/16" holes through the door and secure bracket with 5/16"-18 x 2" carriage bolts, lock washers and nuts (not provided). (Figure 4)

NOTE: The 1/4"-14 x 5/8" self-threading screws are not intended for use on wood doors.

HARDWARE

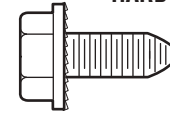

Self-Threading Screw
1/4"-14 x 5/8"

FIGURE 1

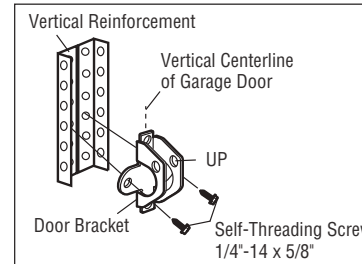

FIGURE 2

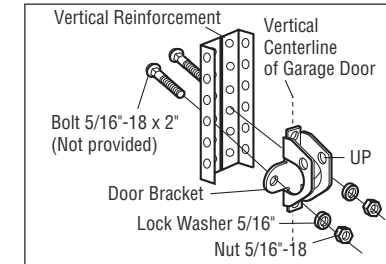

FIGURE 3

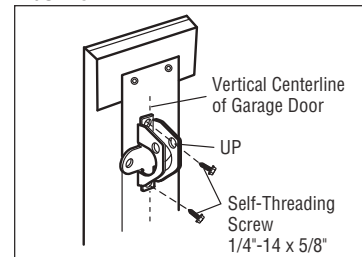
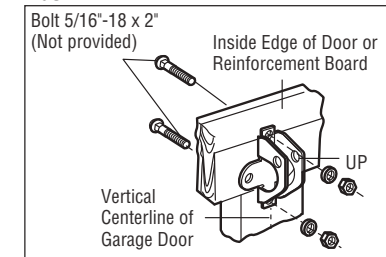

FIGURE 4



Installation

9 Connect the Door Arm to the Trolley

IMPORTANT: The groove on the straight door arm **MUST** face away from the curved door arm.

1. Close the door. Disconnect the trolley by pulling the emergency release handle. Slide the outer trolley back (away from the door) about 2" (5 cm).
2. Attach the straight door arm to the outer trolley using the clevis pin. Attach with the ring fastener.
3. Attach the curved door arm to the door bracket using the clevis pin. Attach with the ring fastener.
4. Align the straight door arm with the curved door arm. Select two aligned holes (as far apart as possible) and attach using the bolts, nuts and lock washers.

NOTE: If the holes do not line up, reverse the straight door arm. Select two aligned holes (as far apart as possible) and attach using the bolts, nuts and lock washers.

5. Pull the emergency release handle toward the garage door opener until the trolley release arm is horizontal. The trolley will re-engage automatically when the garage door opener is activated.

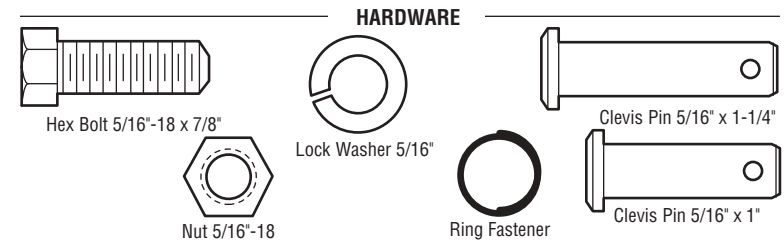

CORRECT

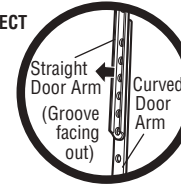

INCORRECT

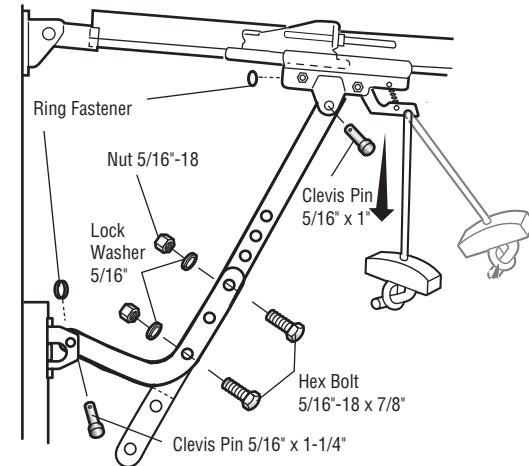
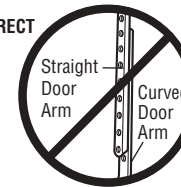

Install the Door Control

1 Install the Door Control

WARNING

To prevent possible **SERIOUS INJURY** or **DEATH** from electrocution:

- Be sure power is **NOT** connected **BEFORE** installing door control.
- Connect door control **ONLY** to 12 VOLT low voltage wires.

To prevent possible **SERIOUS INJURY** or **DEATH** from a closing garage door:

- Install door control within sight of garage door, out of reach of small children at a minimum height of 5 feet (1.5 m) above floors, landings, steps or any other adjacent walking surface, and away from **ALL** moving parts of door.
- **NEVER** permit children to operate or play with door control push buttons or remote control transmitters.
- Activate door **ONLY** when it can be seen clearly, is properly adjusted, and there are no obstructions to door travel.
- **ALWAYS** keep garage door in sight until completely closed. **NEVER** permit anyone to cross path of closing garage door.

INTRODUCTION

Compatible with myQ® and Security+ 2.0 accessories, see page 44. Your garage door opener is compatible with up to 2 Smart Control Panels or 4 of any other Security+ 2.0 door controls.

NOTE: Older LiftMaster door controls and third party products are not compatible.

Install door control within sight of garage door, out of reach of small children at a minimum height of 5 feet (1.5 m) above floors, landings, steps or any other adjacent walking surface, and away from **ALL** moving parts of door. For gang box installations it is not necessary to drill holes or install the drywall anchors. Use the existing holes in the gang box.

NOTE: Your product may look different than the illustrations.

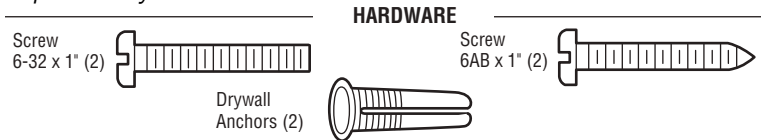

1. Strip 7/16" (11 mm) of insulation from one end of the wire and separate the wires.
2. Connect one wire to each of the two screws on the back of the door control. The wires can be connected to either screw.

PRE-WIRED INSTALLATIONS: Choose any two wires to connect, note which wires are used so the correct wires are connected at the garage door opener in a later step.

3. Mark the location of the bottom mounting hole and drill a 5/32" hole.
4. Install the bottom screw, allowing 1/8" (3 mm) to protrude from the wall.
5. Position the bottom hole of the door control over the screw and slide down into place.
6. Lift the push bar up and mark the top hole.
7. Remove the door control from the wall and drill a 5/32" hole for the top screw.
8. Position the bottom hole of the door control over the screw and slide down into place. Attach the top screw.

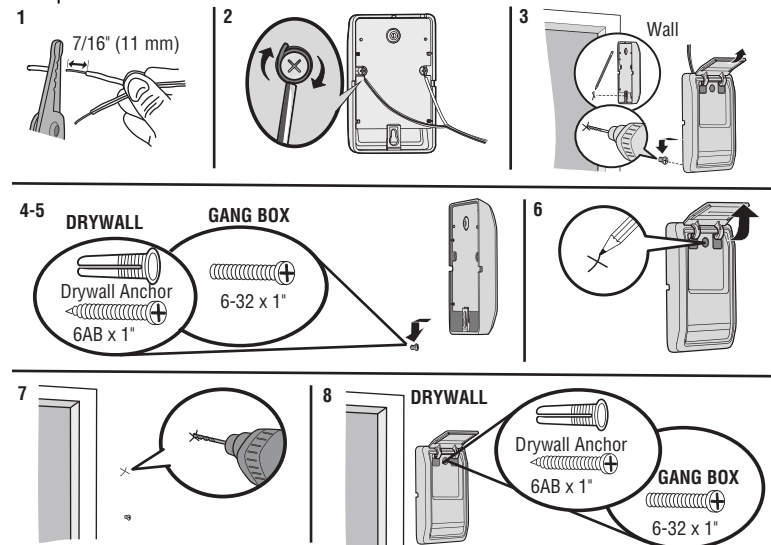

Install the Door Control

2 Wire the Door Control to the Garage Door Opener

PRE-WIRED INSTALLATIONS: When wiring the door control to the garage door opener make sure you use the same wires that are connected to the door control.

1. Run the white and red/white wire from the door control to the garage door opener. Attach the wire to the wall and ceiling with staples (not applicable for gang box or pre-wired installations). Do not pierce the wire with the staple as this may cause a short or an open circuit.
2. Strip 7/16" (11 mm) of insulation from the end of the wire near the garage door opener.
3. Connect the wire to the red and white terminals on the garage door opener. To insert or release wires from the terminal, push in the tab with screwdriver tip.

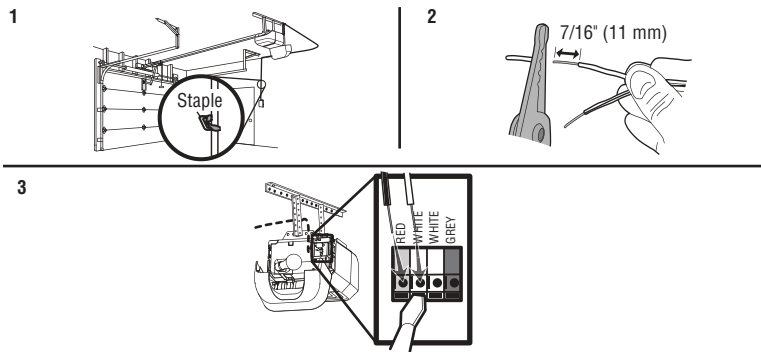

3 Attach the Warning Labels

1. Attach the entrapment warning label on the wall near the door control with tacks or staples.
2. Attach the manual release/safety reverse test label in a visible location on the inside of the garage door.

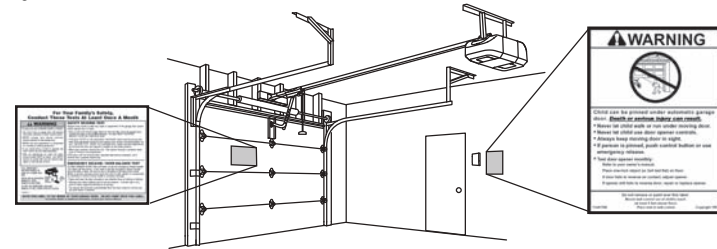

Install the Protector System[®]

Introduction

WARNING

Be sure power is NOT connected to the garage door opener BEFORE installing the safety reversing sensor.

To prevent SERIOUS INJURY or DEATH from closing garage door:

- Correctly connect and align the safety reversing sensor. This required safety device MUST NOT be disabled.
- Install the safety reversing sensor so beam is NO HIGHER than 6" (15 cm) above garage floor.

IMPORTANT INFORMATION ABOUT THE SAFETY REVERSING SENSORS

The safety reversing sensors must be connected and aligned correctly before the garage door opener will move in the down direction.

The sending sensor (with an amber LED) transmits an invisible light beam to the receiving sensor (with a green LED). If an obstruction breaks the light beam while the door is closing, the door will stop and reverse to the full open position, and the garage door opener lights will flash 10 times.

NOTE: For energy efficiency the garage door opener will enter sleep mode when the door is fully closed. The sleep mode shuts the garage door opener down until activated. The sleep mode is sequenced with the garage door opener lights; as the lights turn off, the sensor LEDs will turn off and whenever the garage door opener lights turn on, the sensor LEDs will light. The garage door opener will not go into the sleep mode until the garage door opener has completed 5 cycles upon power up.

When installing the safety reversing sensors check the following:

- Sensors are installed inside the garage, one on either side of the door.
- Sensors are facing each other with the lenses aligned and the receiving sensor lens does not receive direct sunlight.
- Sensors are no more than 6" (15 cm) above the floor and the light beam is unobstructed.

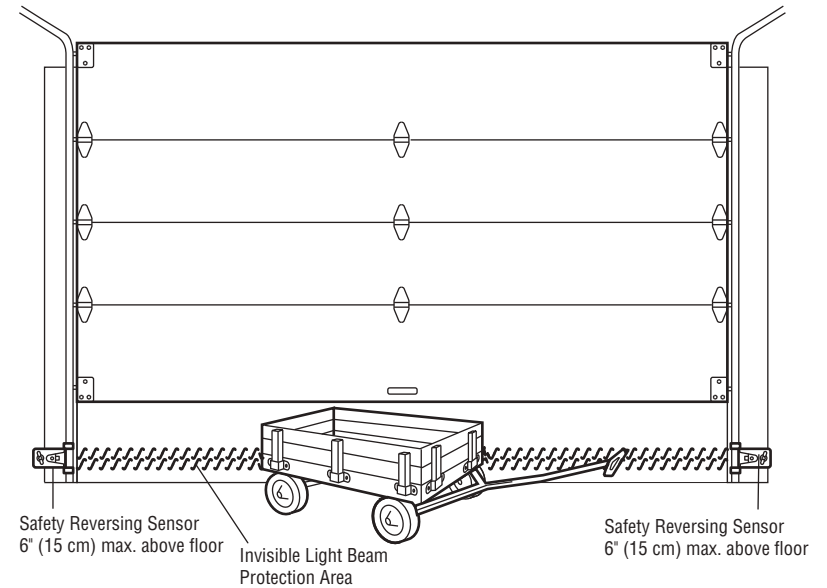

Install the Protector System®

1 Install the Safety Reversing Sensors



The safety reversing sensors can be attached to the door track, the wall, or the floor. If the door track will not support the sensor bracket a wall installation is recommended. Choose one of the following installations.

OPTION A - DOOR TRACK INSTALLATION

1. Slide the curved arms of the sensor bracket around the edge of the door track. Snap into place so that the sensor bracket is flush against the track.
2. Slide the carriage bolt into the slot on each sensor.
3. Insert the bolt through the hole in the sensor bracket and attach with the wing nut. The lenses on both sensors should point toward each other. Make sure the lens is not obstructed by the sensor bracket.

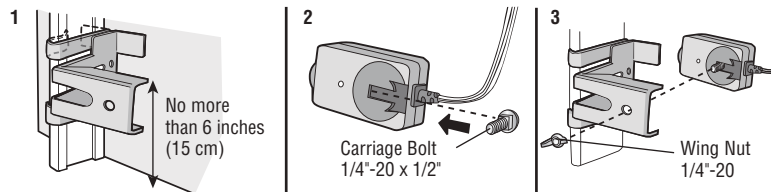

OPTION B - WALL INSTALLATION

If additional clearance is needed an extension bracket (not provided) or wood blocks can be used. Make sure each bracket has the same amount of clearance so they will align correctly.

1. Position the sensor bracket against the wall with the curved arms facing the door. Make sure there is enough clearance for the beam to be unobstructed. Mark holes.
2. Drill 3/16 inch pilot holes for each sensor bracket and attach the sensor brackets to the wall using lag screws (not provided).
3. Slide the carriage bolt into the slot on each sensor.
4. Insert the bolt through the hole in the sensor bracket and attach with the wing nut. The lenses on both sensors should point toward each other. Make sure the lens is not obstructed by the sensor bracket.

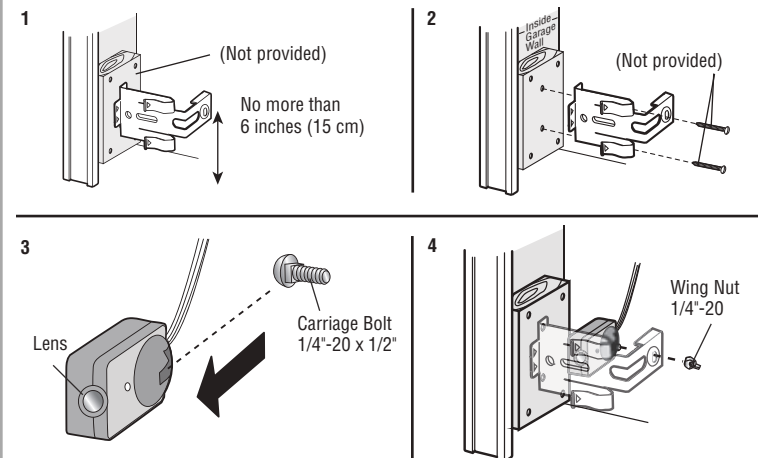

Install the Protector System®

OPTION C - FLOOR INSTALLATION

Use an extension bracket (not provided) or wood block to raise the sensor bracket if needed.

1. Carefully measure the position of both sensor brackets so they will be the same distance from the wall and unobstructed.
2. Attach the sensor brackets to the floor using concrete anchors (not provided).
3. Slide the carriage bolt into the slot on each sensor.
4. Insert the bolt through the hole in the sensor bracket and attach with the wing nut. The lenses on both sensors should point toward each other. Make sure the lens is not obstructed by the sensor bracket.

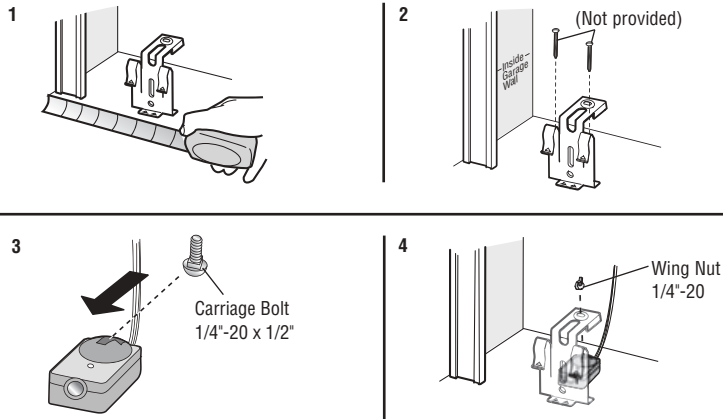

2 Wire the Safety Reversing Sensors

PRE-WIRED INSTALLATIONS: If your garage already has wires installed for the safety reversing sensors, see page 25.

OPTION A - INSTALLATION WITHOUT PRE-WIRING

1. Run the wire from both sensors to the garage door opener. Attach the wire to the wall and ceiling with staples.
2. Strip 7/16" (11 mm) of insulation from each set of wires. Separate the wires. Twist the white wires together. Twist the white/black wires together.
3. Insert the white wires into the white terminal on the garage door opener. Insert the white/black wires into the grey terminal on the garage door opener. To insert or remove the wires from the terminal, push in the tab with a screwdriver tip.

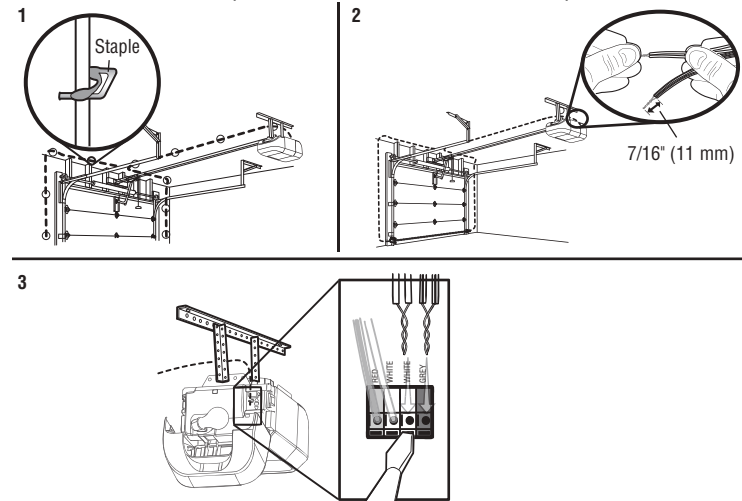

Install the Protector System®

OPTION B - PRE-WIRED INSTALLATION

1. Cut the end of the safety reversing sensor wire, making sure there is enough wire to reach the pre-installed wires from the wall.
2. Separate the safety reversing sensor wires and strip 7/16 inch (11 mm) of insulation from each end. Choose two of the pre-installed wires and strip 7/16 inch (11 mm) of insulation from each end. Make sure that you choose the same color pre-installed wires for each sensor.
3. Connect the pre-installed wires to the sensor wires with wire nuts making sure the colors correspond for each sensor. For example, the white wire would connect to the yellow wire and the white/black wire would connect to the purple wire.
4. At the garage door opener, strip 7/16 inch (11 mm) of insulation from each end of the wires previously chosen for the safety reversing sensors. Twist the like-colored wires together.
5. Insert the wires connected to the white safety sensor wires to the white terminal on the garage door opener. Insert the wires that are connected to the white/black safety sensor wires to the grey terminal on the garage door opener.

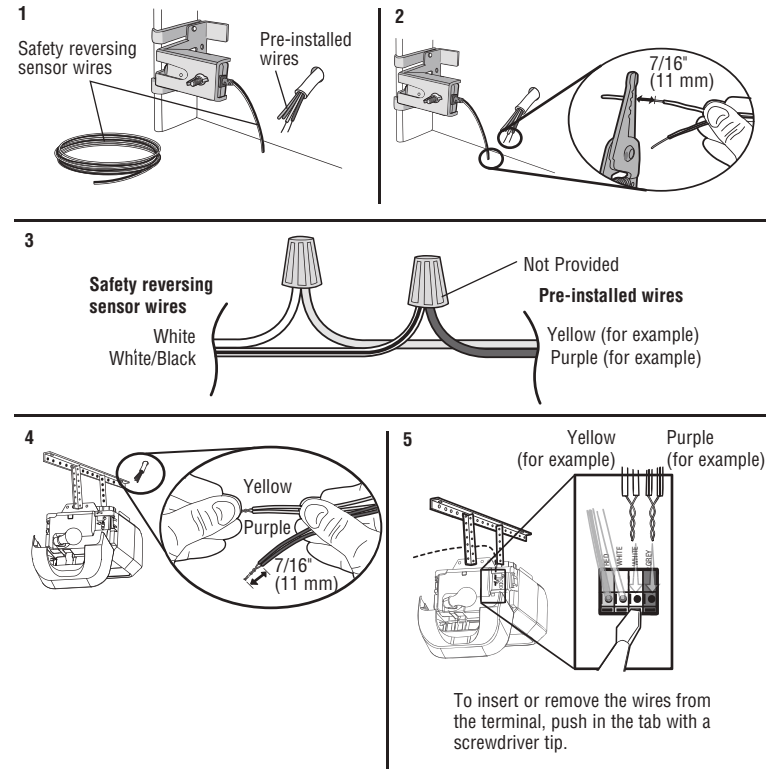

Power

1 Connect Power

WARNING

To prevent possible **SERIOUS INJURY** or **DEATH** from electrocution or fire:

- Be sure power is **NOT** connected to the opener, and disconnect power to circuit **BEFORE** removing cover to establish permanent wiring connection.
- Garage door installation and wiring **MUST** be in compliance with **ALL** local electrical and building codes.
- **NEVER** use an extension cord, 2-wire adapter, or change plug in **ANY** way to make it fit outlet. Be sure the opener is grounded.

To avoid installation difficulties, do not activate the garage door opener at this time.

To reduce the risk of electric shock, your garage door opener has a grounding type plug with a third grounding pin. This plug will only fit into a grounding type outlet. If the plug doesn't fit into your outlet, contact a qualified electrician to install the proper outlet.

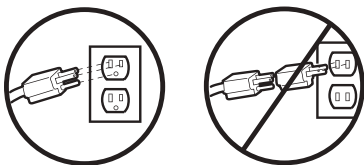

THERE ARE TWO OPTIONS FOR CONNECTING POWER:

OPTION A - TYPICAL WIRING

1. Plug in the garage door opener into a grounded outlet.
2. **DO NOT** run garage door opener at this time.

TYPICAL WIRING

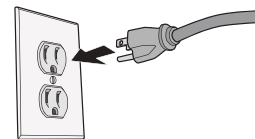

OPTION B - PERMANENT WIRING

If permanent wiring is required by your local code, refer to the following procedure. To make a permanent connection through the 7/8 inch hole in the top of the motor unit (according to local code):

1. Remove the motor unit cover screws and set the cover aside.
2. Remove the attached 3-prong cord.
3. Connect the black (line) wire to the screw on the brass terminal; the white (neutral) wire to the screw on the silver terminal; and the ground wire to the green ground screw. **The opener must be grounded.**
4. Reinstall the cover.

PERMANENT WIRING

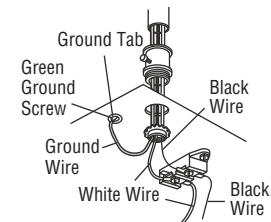

Power

2 Ensure the Safety Reversing Sensors are Aligned

The door will not close if the sensors have not been installed and aligned correctly.

When the light beam is obstructed or misaligned while the door is closing, the door will reverse and the garage door opener lights will flash ten times. If the door is already open, it will not close. The sensors can be aligned by loosening the wing nuts, aligning the sensors, and tightening the wing nuts.

1. Check to make sure the LEDs in both sensors are glowing steadily. The LEDs in both sensors will glow steadily if they are aligned and wired correctly.

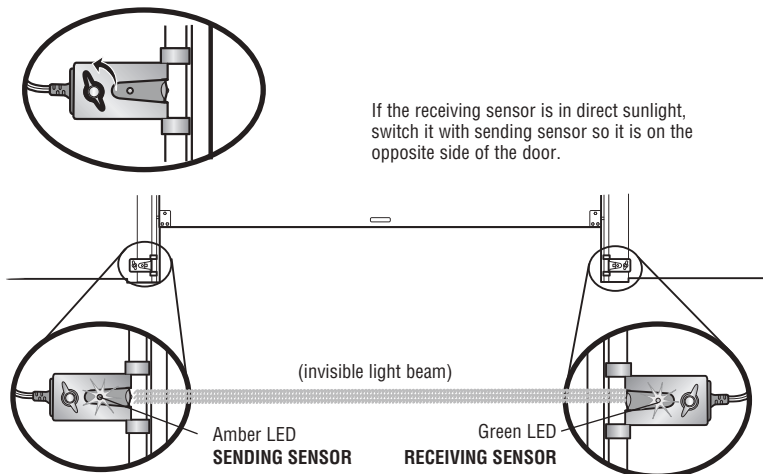

IF THE AMBER LED ON THE SENDING SENSOR IS NOT GLOWING:

1. Make sure there is power to the garage door opener.
2. Make sure the sensor wire is not shorted/broken.
3. Make sure the sensor has been wired correctly: White wires to white terminal and white/black wires to gray terminal.

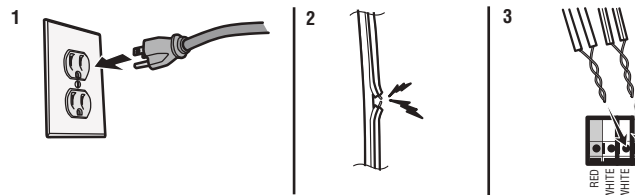

IF THE GREEN LED ON THE RECEIVING SENSOR IS NOT GLOWING:

1. Make sure the sensor wire is not shorted/broken.
2. Make sure the sensors are aligned.

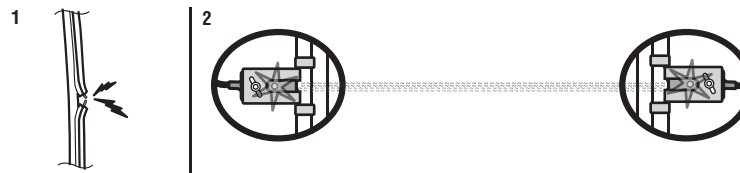

3 Ensure the Door Control is Wired Correctly

If the door control has been installed and wired correctly a message will display on the screen.

Adjustments

Introduction

WARNING

Without a properly installed safety reversal system, persons (particularly small children) could be SERIOUSLY INJURED or KILLED by a closing garage door.

- Incorrect adjustment of garage door travel limits will interfere with proper operation of safety reversal system.
- After ANY adjustments are made, the safety reversal system MUST be tested. Door MUST reverse on contact with 1-1/2" (3.8 cm) high object (or 2x4 laid flat) on floor.

CAUTION

To prevent damage to vehicles, be sure fully open door provides adequate clearance.

Your garage door opener is designed with electronic controls to make setup and adjustments easy. The adjustments allow you to program where the door will stop in the open (UP) and close (DOWN) position. The electronic controls sense the amount of force required to open and close the door. The force is adjusted automatically when you program the travel.

NOTE: If anything interferes with the door's upward travel it will stop. If anything interferes with the door's downward travel, it will reverse.

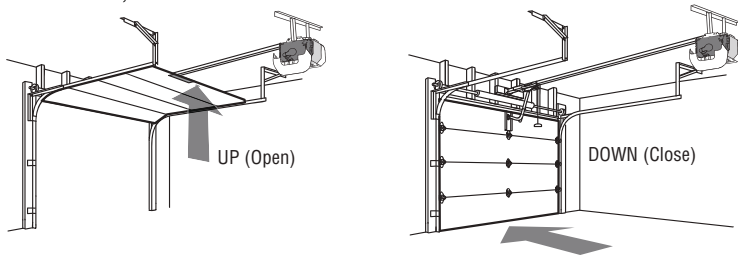

PROGRAMMING BUTTONS

The programming buttons are located on the left side panel of the garage door opener and are used to program the travel. While programming, the UP and DOWN buttons can be used to move the door as needed.

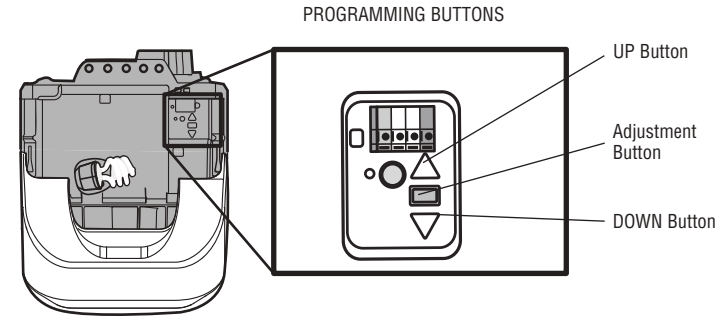

Adjustments

1 Program the Travel

WARNING

Without a properly installed safety reversal system, persons (particularly small children) could be SERIOUSLY INJURED or KILLED by a closing garage door.

- Incorrect adjustment of garage door travel limits will interfere with proper operation of safety reversal system.
- After ANY adjustments are made, the safety reversal system MUST be tested. Door MUST reverse on contact with 1-1/2" (3.8 cm) high object (or 2x4 laid flat) on floor.

While programming, the UP and DOWN buttons can be used to move the door as needed.

1. Press and hold the Adjustment Button until the UP Button begins to flash and/or a beep is heard.
2. Press and hold the UP Button until the door is in the desired UP position.
3. Once the door is in the desired UP position press and release the Adjustment Button. The garage door opener lights will flash twice and the DOWN Button will begin to flash.
4. Press and hold the DOWN button until the door is in the desired DOWN position.
5. Once the door is in the desired DOWN position press and release the Adjustment Button. The garage door opener lights will flash twice and the UP Button will begin to flash.
6. Press and release the UP Button. When the door travels to the programmed UP position, the DOWN Button will begin to flash.
7. Press and release the DOWN Button. The door will travel to the programmed DOWN position. Programming is complete.

If the garage door opener lights are flashing 5 times during the steps for Program the Travel, the programming has timed out. If the garage door opener lights are flashing 10 times during the steps for Program the Travel, the safety reversing sensors are misaligned or obstructed (refer to page 27). When the sensors are aligned and unobstructed, cycle the door through a complete up and down cycle using the remote control or the UP and DOWN buttons. Programming is complete. If you are unable to operate the door up and down, repeat the steps for Programming the Travel.

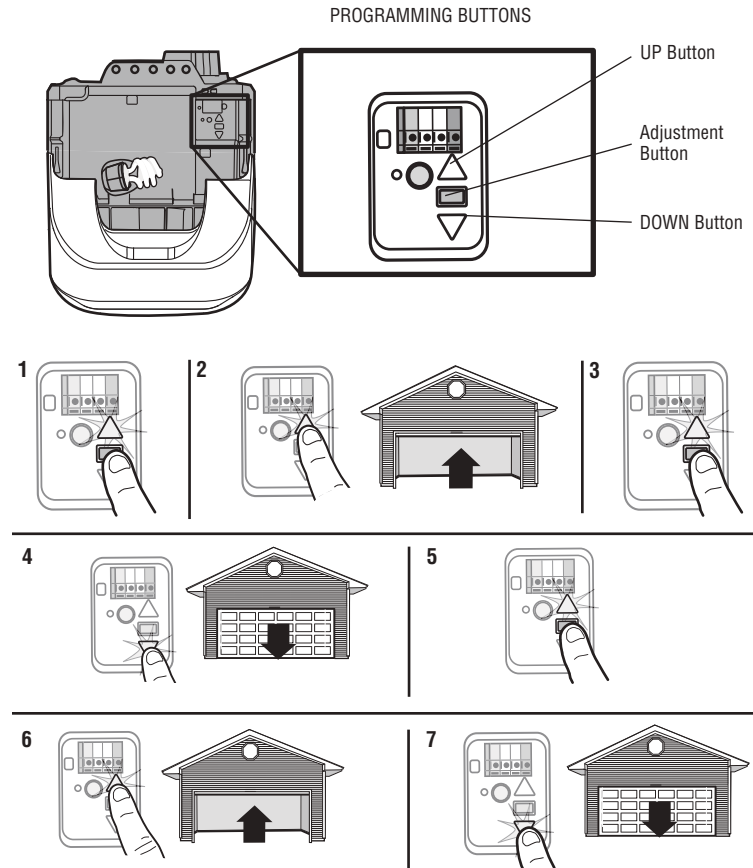

Adjustments

2 Test the Safety Reversal System

WARNING

Without a properly installed safety reversal system, persons (particularly small children) could be SERIOUSLY INJURED or KILLED by a closing garage door.

- Safety reversal system **MUST** be tested every month.
- After ANY adjustments are made, the safety reversal system **MUST** be tested. Door **MUST** reverse on contact with 1-1/2" (3.8 cm) high object (or 2x4 laid flat) on the floor.

1. With the door fully open, place a 1-1/2" (3.8 cm) board (or a 2x4 laid flat) on the floor, centered under the garage door.
2. Press the remote control push button to close the door. The door **MUST** reverse when it makes contact with the board.

If the door stops but does not reverse:

1. Review the installation instructions provided to insure all steps were followed;
2. Repeat Program the Travel (see Adjustment Step 1);
3. Repeat the Safety Reversal test.

If the test continues to fail, call a trained door systems technician.

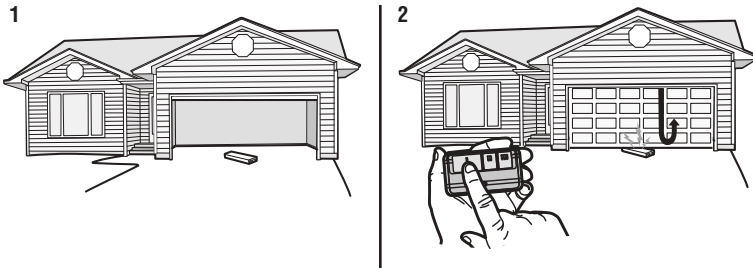

3 Test the Protector System®

WARNING

Without a properly installed safety reversing sensor, persons (particularly small children) could be SERIOUSLY INJURED or KILLED by a closing garage door.

1. Open the door. Place the garage door opener carton in the path of the door.
2. Press the remote control push button to close the door. The door will not move more than 1" (2.5 cm), and the garage door opener lights will flash 10 times.

The garage door opener will not close from a remote control if the LED in either safety reversing sensor is off (alerting you to the fact that the sensor is misaligned or obstructed). If the garage door opener closes the door when the safety reversing sensor is obstructed (and the sensors are no more than 6" [15 cm] above the floor), call for a trained door systems technician.

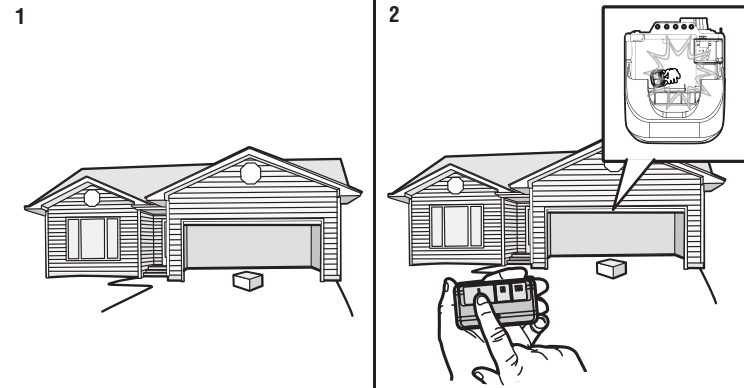

Battery Backup

1 Install the Battery*

WARNING

To reduce the risk of FIRE or INJURY to persons:

- Disconnect ALL electric and battery power BEFORE performing ANY service or maintenance.
- Use ONLY LiftMaster part # 485LM for replacement battery.
- DO NOT dispose of battery in fire. Battery may explode. Check with local codes for disposal instructions.

CAUTION

ALWAYS wear protective gloves and eye protection when changing the battery or working around the battery compartment.

1. Unplug the garage door opener.
2. Open the light lens. Use a Phillips head screwdriver to remove the battery cover on the garage door opener.
3. Partially insert the battery into the battery compartment with the terminals facing out.
4. Connect red (+) and black (-) wires from the garage door opener to the corresponding terminals on the battery.
5. Replace the battery cover.
6. Plug in the garage door opener.
7. Wait for the green Battery Status LED to start flashing before proceeding to test the battery.

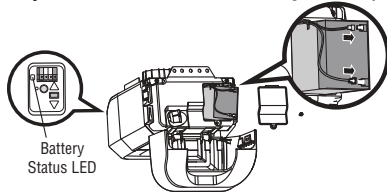

* If applicable

2 Test the Battery

1. Unplug the garage door opener. The battery status LED will either glow solid orange indicating opener is operating on battery power or will flash indicating low battery power. **NOTE: Make sure the garage door opener is unplugged.**
2. Open and close the door using the remote control or door control. **NOTE: The garage door opener may run slower if the battery is not fully charged. The battery will take 24 hours to fully charge.**
3. Plug in the garage door opener. Verify the battery status LED is flashing green, indicating the battery is charging.

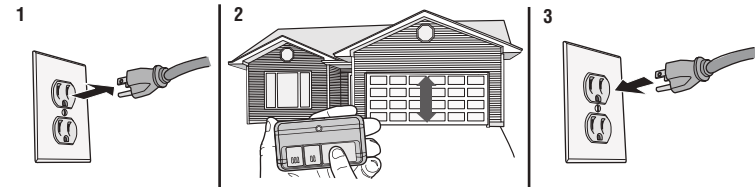

Battery Backup

3 Charge the Battery*

The battery charges when the garage door opener is plugged into a 120Vac electrical outlet that has power and requires 24 hours to fully charge. A fully charged battery supplies 12Vdc to the garage door opener for one to two days of normal operation during an electrical power outage. After the electrical power has been restored, the battery will recharge within 24 hours. The battery will last approximately 1 to 2 years with normal usage. Instructions for replacement are provided with the battery. To obtain maximum battery life and prevent damage, disconnect the battery when the garage door opener is unplugged for an extended period of time, such as a summer or winter home.

NOTE: When the garage door opener is in battery backup mode the garage door opener lights, Timer-to-Close, remote close, and camera features are unavailable. In battery backup mode, the Automatic Garage Door Lock will unlock when the garage door is opened, and will remain disabled until power is restored.

* If applicable.

4 Battery Status LED

GREEN LED:

All systems are normal.

- A solid green LED light indicates the battery is fully charged.
- A flashing green LED indicates the battery is being charged.

ORANGE LED:

The garage door opener has lost power and is in battery backup mode.

- A solid orange LED with beep, sounding approximately every 2 seconds, indicates the garage door opener is operating on battery power.
- A flashing orange LED with beep, sounding every 30 seconds, indicates the battery is low.

RED LED:

The garage door opener's 12V battery needs to be replaced.

- A solid red LED with beep, sounding every 30 seconds, indicates the 12V battery will no longer hold a charge and needs to be replaced. Replace the battery back up to maintain the battery backup feature.

NOTE: The Battery Status LED is most visible with the garage door opener light off. Battery does not have to be fully charged to operate the garage door opener.

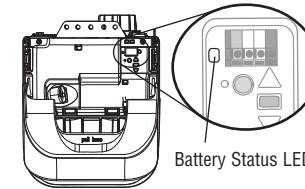

IMPORTANT SAFETY INSTRUCTIONS

WARNING

To reduce the risk of SEVERE INJURY or DEATH:

1. READ AND FOLLOW ALL WARNINGS AND INSTRUCTIONS.
2. ALWAYS keep remote controls out of reach of children. NEVER permit children to operate or play with garage door control push buttons or remote controls.
3. ONLY activate garage door when it can be seen clearly, it is properly adjusted, and there are no obstructions to door travel.
4. ALWAYS keep garage door in sight and away from people and objects until completely closed. NO ONE SHOULD CROSS THE PATH OF THE MOVING DOOR.
5. NO ONE SHOULD GO UNDER A STOPPED, PARTIALLY OPENED DOOR.
6. If possible, use emergency release handle to disengage trolley ONLY when garage door is CLOSED. Use caution when using this release with the door open. Weak or broken springs or unbalanced door could result in an open door falling rapidly and/or unexpectedly and increasing the risk of SEVERE INJURY or DEATH.
7. NEVER use emergency release handle unless garage doorway is clear of persons and obstructions.
8. NEVER use handle to pull garage door open or closed. If rope knot becomes untied, you could fall.
9. After ANY adjustments are made, the safety reversal system MUST be tested.
10. Safety reversal system MUST be tested every month. Garage door MUST reverse on contact with 1-1/2" (3.8 cm) high object (or a 2x4 laid flat) on the floor. Failure to adjust the garage door opener properly increases the risk of SEVERE INJURY or DEATH.
11. ALWAYS KEEP GARAGE DOOR PROPERLY BALANCED (see page 4). An improperly balanced door may NOT reverse when required and could result in SEVERE INJURY or DEATH.
12. ALL repairs to cables, spring assemblies and other hardware, ALL of which are under EXTREME tension, MUST be made by a trained door systems technician.
13. To avoid SERIOUS PERSONAL INJURY or DEATH from electrocution, disconnect ALL electric and battery power BEFORE performing ANY service or maintenance.
14. This operator system is equipped with an unattended operation feature. The door could move unexpectedly. NO ONE SHOULD CROSS THE PATH OF THE MOVING DOOR.
15. DO NOT install on a one-piece door if using devices or features providing unattended close. Unattended devices and features are to be used ONLY with sectional doors.

16. SAVE THESE INSTRUCTIONS.

Operation

Features

Your garage door opener is equipped with features to provide you with greater control over your garage door operation.

ALERT2CLOSE

The Alert2Close feature provides a visual and an audible alert that an unattended door is closing.

TIMER-TO-CLOSE (TTC)

The TTC feature automatically closes the door after a specified time period that can be adjusted using a TTC enabled door control (Models 881LMW or 880LMW). Prior to and during the door closing the garage door opener lights will flash and the garage door opener will beep.

MYQ

myQ® allows you to control your garage door opener from your mobile device or computer from anywhere. myQ® technology uses a 900Mhz signal to provide two way communication between the garage door opener and myQ® enabled accessories.

The garage door opener has an internal gateway that allows the garage door opener to communicate directly with a home Wi-Fi® network and access your myQ® account.

THE PROTECTOR SYSTEM® (SAFETY REVERSING SENSORS)

When properly connected and aligned, the safety reversing sensors will detect an obstruction in the path of the infrared beam. If an obstruction breaks the infrared beam while the door is closing, the door will stop and reverse to full open position, and the opener lights will flash 10 times. If the door is fully open, and the safety reversing sensors are not installed, or are misaligned, the door will not close from a remote control. However, you can close the door if you hold the button on the door control or keyless entry until the door is fully closed. The safety reversing sensors do not affect the opening cycle. For more information see page 22.

ENERGY CONSERVATION

For energy efficiency the garage door opener will enter sleep mode when the door is fully closed. The sleep mode shuts the garage door opener down until activated. The sleep mode is sequenced with the garage door opener light bulb; as the light bulb turns off the sensor LEDs will turn off and whenever the garage door opener lights turn on the sensor LEDs will light. The garage door opener will not go into the sleep mode until the garage door opener has completed 5 cycles upon power up.

LIGHTS

The garage door opener light bulbs will turn on when the opener is initially plugged in; power is restored after interruption, or when the garage door opener is activated. The lights will turn off automatically after 4-1/2 minutes. An incandescent A19 light bulb (100 watt maximum) or for maximum energy efficiency a 26W (100W equivalent) compact fluorescent light (CFL) bulb may be used.

Light Feature

The garage door opener is equipped with an added feature; the lights will turn on when someone enters through the open garage door and the safety reversing sensor infrared beam is broken. For added control over the light bulbs on your garage door opener, see page 38.

USING YOUR GARAGE DOOR OPENER

The garage door opener can be activated through a wall-mounted door control, remote control, wireless keyless entry or myQ® accessory. When the door is closed and the garage door opener is activated the door will open. If the door senses an obstruction or is interrupted while opening the door will stop. When the door is in any position other than closed and the garage door opener is activated the door will close. If the garage door opener senses an obstruction while closing, the door will reverse. If the obstruction interrupts the sensor beam the garage door opener lights will blink 10 times. However, you can close the door if you hold the button on the door control or keyless entry until the door is fully closed. The safety reversing sensors do not affect the opening cycle. The safety reversing sensor must be connected and aligned correctly before the garage door opener will move in the down direction.

BATTERY BACKUP*

The battery backup system allows access in and out of your garage, even when the power is out. When the garage door opener is operating on battery power, the garage door opener will run slower, the light will not function, the Battery Status LED will glow solid orange, and a beep will sound approximately every 2 seconds.

AUTOMATIC GARAGE DOOR LOCK*



Garage door opener models featuring the Security Shield are compatible with the LiftMaster Automatic Garage Door Lock (Model 841LM). See Accessories, page 44.

CAMERA*

Live stream what is happening in your garage with your garage door opener's built-in camera. Just connect your opener to Wi-Fi and set up an account with the myQ® App. For more information, see page 36.

* If applicable.

Operation

Connect With Your Smartphone

The Wi-Fi Garage Door Opener is compatible with up to 16 myQ® enabled accessories. Up to 10 devices can be paired to the Wi-Fi garage door opener's internal gateway. These devices can be controlled with the myQ® App. These devices include any combination of myQ® garage door openers, Wi-Fi garage door openers, myQ® light controls, myQ® gate operators or myQ® commercial door operators. A LiftMaster Internet Gateway (828LM) can be added if you need to control more than 10 devices using the myQ® App. Up to 6 devices can be paired to garage door opener itself (controlled by garage door opener through 900MHz). These devices include any combination of myQ® light controls or a garage door and gate monitor.

YOU WILL NEED:

- Wi-Fi enabled smartphone, tablet or laptop
- Broadband Internet Connection
- Wi-Fi signal in the garage (**2.4 GHz, 802.11b/g/n required**), see page 4
- Password for your home network (router's main account, not guest network)
- myQ® serial number located on the garage door opener

DOWNLOAD THE myQ® APP TO SET UP AN ACCOUNT AND CONNECT

Open and close your door, get alerts and set schedules from anywhere. Connected smart garage door openers also receive software updates to ensure the opener has the latest operational features.

1. Download the myQ® App.
2. Set up an account and connect.

For more information on connecting your garage door opener, visit support.chamberlaingroup.com.

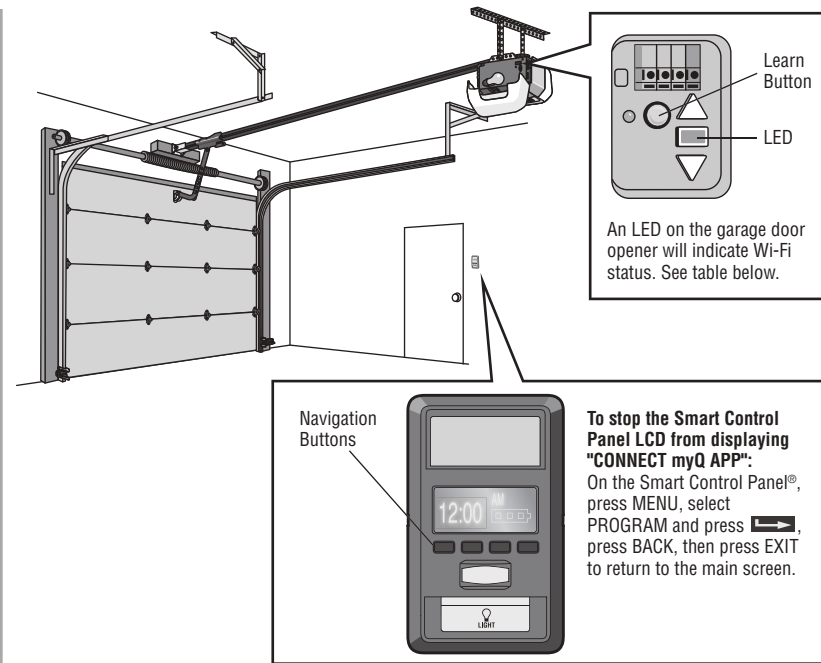

WiFi Status	
LED	Definition
Blue	Off - Wi-Fi is not turned on. Blinking - Garage door opener is in Wi-Fi learn mode. Solid - Mobile device connected to the garage door opener.
Blue and Green	Blinking - Attempting to connect to router.
Green	Blinking - Attempting to connect to the Internet server. Solid - Wi-Fi has been set up and garage door opener is connected to the internet.

NOTES:

myQ® App control WILL NOT work if the garage door opener is operating on battery power.

To erase the Wi-Fi settings, see page 39.

Operation

Set Up the Camera - Models 85503 and 85503-267

1. Download the myQ® app and setup your account if you haven't already, see page 35.
 2. Follow the instructions in the app to setup and use the camera.
- The camera powers up when it is opened and powers down when closed.

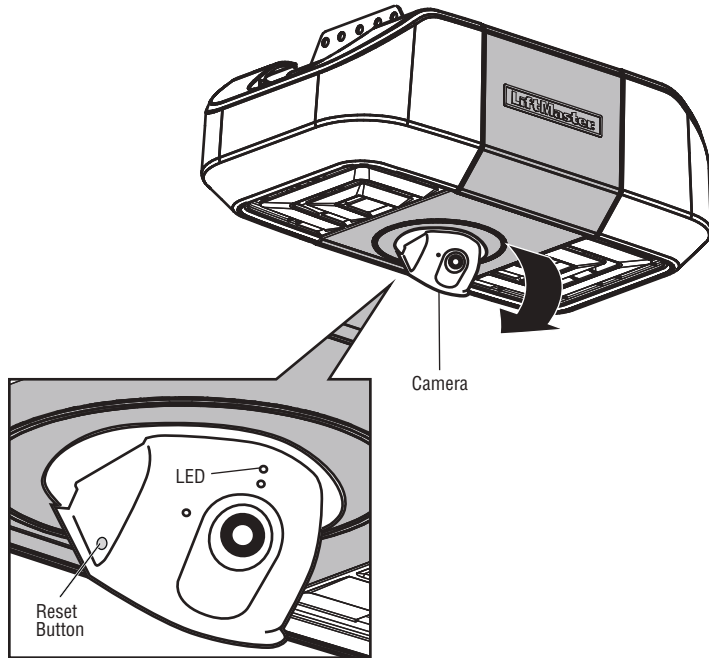

Camera Status	
LED	Definition
Flashing Blue	Camera is attempting to connect to the mobile device.
Solid Blue	Camera is connected to the mobile device.
Flashing Blue and Green	Camera is attempting to connect to the router.
Flashing Green	Camera is connected to the router and attempting to connect to myQ® server.
Solid Green	Camera is connected and working normally.
Solid White	Camera is booting.
Flashing Red	Camera is overheating.
Flashing Purple	Camera firmware is updating.

For more information on using the camera, visit support.chamberlaingroup.com.

Operation

Using the Door Control

SYNCHRONIZE THE DOOR CONTROL

To synchronize the door control to the garage door opener, press the push bar until the garage door opener activates (it may take up to 3 presses). Test the door control by pressing the push bar, each press of the push bar will activate the garage door opener.

Up to 2 Smart Control Panels® or 4 of any other Security+ 2.0 door controls can be connected to the garage door opener.

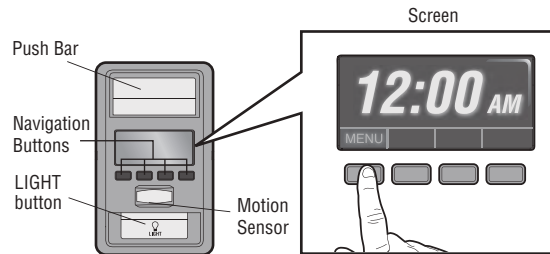

PUSH BAR

Press the push bar to open or close the door.

NAVIGATION BUTTONS

Use the navigation buttons to make selections and program features.

LIGHT BUTTON

Press the LIGHT button to turn the garage door opener lights on or off. When the lights are turned on they will stay on until the LIGHT button is pressed again, or until the garage door opener is activated. Once the garage door opener is activated the lights will turn off after the specified period of time (the factory setting is 4-1/2 minutes). The LIGHT button will not control the lights when the door is in motion.

SCREEN

The screen will display the time and temperature until the menu button is pressed, and then it will display the menu options. If there is a problem with the garage door opener the screen will display the Diagnostic Code. Refer to the Troubleshooting section.

The following features are accessible through the screen using the navigation buttons:

LEARN A DEVICE

Any compatible remote controls, wireless keyless entry, Wi-Fi garage door openers, or myQ® accessories can be programmed to the garage door opener by accessing the menu and using the navigation buttons.

LOCK

The LOCK feature is designed to prevent activation of the garage door opener from remote controls while still allowing activation from the door control and keyless entry. This feature is useful for added peace of mind when the home is empty (i.e. vacation).

TIMER-TO-CLOSE (TTC)

DO NOT enable TTC if operating a one-piece door. TTC is to be used ONLY with sectional doors. Factory default is set to off. TTC can be set to automatically close your garage door from the fully open position after a specified period of time (1, 5, 10 minute intervals or a custom setting up to 99 minutes). The garage door opener will *Beep* and the lights will *Flash* before closing the door. The screen on the door control can display the status of the TTC. TTC WILL NOT work if the garage door opener is operating by battery power or if the safety reversing sensors are misaligned. This feature is NOT intended to be the primary method of closing the door. **A keyless entry should be installed in the event of an accidental lock out when using this feature.**

Before enabling the TTC for the first time, or if you experience a power outage, cycle the garage door opener open and closed to allow the TTC to set.

AUTOMATIC LIGHT

Motion Sensor

Factory default is set to on. This feature automatically turns on the garage door opener lights when motion is sensed. The lights will come on for the set period of time, then shut off. If using the garage door opener light as a work light disable the motion sensor, otherwise the light will turn off automatically if you are beyond the range of the sensor.

Light Feature

The lights will turn on when someone enters through the open garage door and the safety reversing sensor infrared beam is broken.

MAINTENANCE ALERT (MAS)

This feature assists the homeowner in ensuring the garage door opener system stays in good working condition. When the garage door opener needs to be serviced (approximately 4500 garage door opener cycles) the command (yellow) and service (red) LEDs will begin to alternately flash back and forth. The factory setting for the MAS feature is off and can be activated at time of installation. Contact your installing dealer for service.

Operation

Using the Door Control

SETUP

The features on the door control can be programmed through a series of menus on the screen and the navigation buttons. Refer to the descriptions below.

SCREEN

The main screen displays the time, temperature, and current battery charge (if applicable)

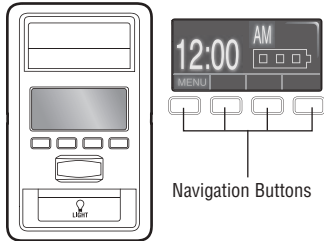

FEATURES

Press the navigation button below "MENU" to view the Features menu.

CLOCK SETUP Set the time, choose 12 or 24 hour clock and show/hide clock.

TTC OFF For sectional doors ONLY. Set the Timer-to-Close feature off/on and set the time interval before door closes. **NOTE: DO NOT enable TTC if operating a one-piece door. TTC is to be used ONLY with sectional doors.**

LOCK DISABLED Enable/disable lock.

PROGRAM Set up Wi-Fi*, add remote controls, myQ® devices, an extra remote button to control your garage door opener lights, or a keyless entry.

EXIT

* The garage door opener must run through a complete cycle before it will activate Wi-Fi® programming. For help related to Wi-Fi, visit LiftMaster.com/Customer-Support.

SETTINGS

Press the navigation button below the down arrow till you see TEMPERATURE to view the Settings menu.

TEMPERATURE Display the temperature in Fahrenheit or Celsius and show/hide the temperature.

LANGUAGE ENGLISH Select a language.

LIGHT SETTINGS Set duration for garage door opener light to stay on after operation, selectable range of 1-1/2 to 4-1/2 minutes. Turn the Motion sensor off/on, and turn the entry light feature off/on.

CONTRAST ADJUST 50 Adjust the contrast of the screen.

EXIT

SERVICE

Press and hold the LIGHT button, then press the second navigation button to view the Service menu.

SOFTWARE REVISION Displays software version information.

CYCLE COUNT Turn the Maintenance Alert (MAS) on/off.

TRANSMITTERS Displays the number of remote controls, myQ® devices, door controls and keyless entries currently programmed to operate the garage door opener.

DISPLAY ERROR Displays any errors that have occurred.

EXIT

To program a remote control or keyless entry to the garage door opener using the door control, see 39.

Operation

Remote Control

Your remote control has been programmed at the factory to operate with your garage door opener.

Up to 12 Security+ 2.0 remote controls can be programmed to the garage door opener. Older LiftMaster remote controls are NOT compatible, see page 44 for compatible accessories. To program additional accessories refer to the instructions provided with the accessory or visit LiftMaster.com. If your vehicle is equipped with a Homelink®, you may require an external adapter depending on the make, model, and year of your vehicle. Visit www.homelink.com for additional information.

TO ADD, REPROGRAM, OR CHANGE A REMOTE CONTROL/KEYLESS ENTRY PIN USING THE DOOR CONTROL

1. Press the navigation button below "MENU" to view the Features menu.
2. Use the navigation buttons to scroll to "PROGRAM".
3. Select "REMOTE" or "KEYPAD" to program from the program menu.
4. **Remote Control:** Press the button on the remote control that you wish to operate your garage door.

Keyless Entry: Enter a 4-digit personal identification number (PIN) of your choice on the keyless entry keypad. Then press the ENTER button.

The garage door opener lights will flash (or two clicks will be heard) when the code has been programmed. Repeat the steps above for programming additional remote controls or keyless entry devices. If programming is unsuccessful, program the remote using the learn button.

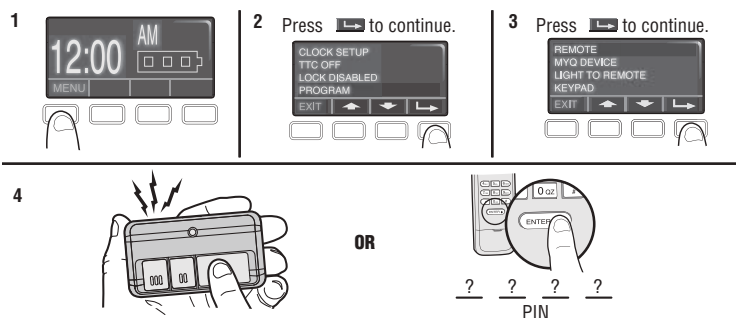

TO ADD, REPROGRAM, OR CHANGE A REMOTE CONTROL USING THE LEARN BUTTON

1. Press and release the LEARN Button on the garage door opener.
2. Press and hold the button on the remote control that you wish to use. Release the button when the garage door opener lights blink or two clicks are heard.

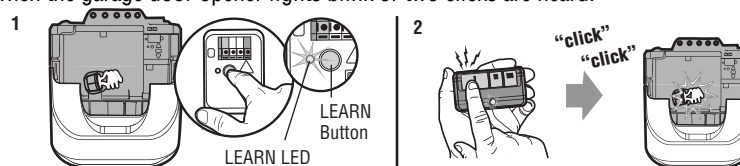

To Erase the Memory

ERASE ALL REMOTE CONTROLS AND KEYLESS ENTRIES

1. Press and hold the LEARN button on garage door opener until the learn LED goes out (approximately 6 seconds). All remote control and keyless entry codes are now erased. Reprogram any accessory you wish to use.

ERASE ALL DEVICES (INCLUDING myQ® ENABLED ACCESSORIES)

1. Press and hold the LEARN button on garage door opener until the learn LED goes out (approximately 6 seconds).
2. Immediately press and hold the LEARN button again until the learn LED goes out. All codes are now erased. Reprogram any accessory you wish to use.

ERASE THE Wi-Fi NETWORK FROM THE GARAGE DOOR OPENER

1. Press and hold the black adjustment button on the garage door opener until 3 beeps are heard (Approximately 6 seconds).

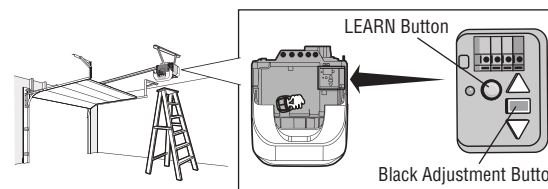

ERASE THE CAMERA SETTINGS

1. Press and hold the reset button on the side of the camera for 10 seconds. The LED light will turn off, then flash red. You will need to set up your camera again after resetting it.

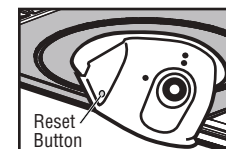

Operation

To Open the Door Manually

WARNING

To prevent possible **SERIOUS INJURY** or **DEATH** from a falling garage door:

- If possible, use emergency release handle to disengage trolley **ONLY** when garage door is **CLOSED**. Weak or broken springs or unbalanced door could result in an open door falling rapidly and/or unexpectedly.
- **NEVER** use emergency release handle unless garage doorway is clear of persons and obstructions.
- **NEVER** use handle to pull door open or closed. If rope knot becomes untied, you could fall.

NOTE: *Disengage any door locks before proceeding.*

DISCONNECT THE TROLLEY

1. The door should be fully closed if possible.
2. Pull down on the emergency release handle.

RECONNECT THE TROLLEY

The lockout feature prevents the trolley from reconnecting automatically.

1. Pull the emergency release handle down and back (toward the opener). The door can then be raised and lowered manually as often as necessary.
2. To disengage the lockout feature, pull the handle straight down. The trolley will reconnect on the next UP or DOWN operation, either manually or by using the door control or remote control.

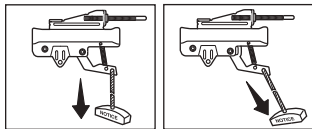

TO MANUALLY DISENGAGE AUTOMATIC GARAGE DOOR LOCK (MODEL 841LM)*

1. The door should be fully closed if possible.
2. Disengage the automatic garage door lock by sliding the manual release to the open position.
3. Pull the emergency release handle down and back (toward the garage door opener). The garage door can then be raised and lowered manually as necessary.
4. To reconnect the trolley, pull the emergency release handle straight down. The trolley will reconnect on the next UP or DOWN operation.

NOTE: *The automatic garage door lock will re-engage when garage door opener operation resumes.*

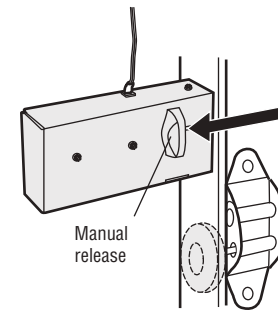

* If applicable.

Maintenance

Maintenance Schedule

EVERY MONTH

- Manually operate door. If it is unbalanced or binding, call a trained door systems technician.
- Check to be sure door opens and closes fully. Adjust if necessary, see page 29.
- Test the safety reversal system. Adjust if necessary, see page 30.

EVERY YEAR

- Oil door rollers, bearings and hinges. The garage door opener does not require additional lubrication. Do not grease the door tracks.
- Test the battery and consider replacing the battery to ensure the garage door opener will operate during an electrical power outage, see page 31 to test the battery backup.

EVERY TWO TO THREE YEARS

- Use a rag to wipe away the existing grease from the garage door opener rail. Reapply a small layer of white lithium grease to the top and underside of the rail surface where the trolley slides.

NOTICE: This device complies with Part 15 of the FCC rules and Industry Canada's license-exempt RSSs. Operation is subject to the following two conditions: (1) this device may not cause harmful interference, and (2) this device must accept any interference received, including interference that may cause undesired operation.

Any changes or modifications not expressly approved by the party responsible for compliance could void the user's authority to operate the equipment.

This device must be installed to ensure a minimum 20 cm (8 in.) distance is maintained between users/bystanders and device.

This device has been tested and found to comply with the limits for a Class B digital device, pursuant to part 15 of the FCC rules and Industry Canada ICES standard. These limits are designed to provide reasonable protection against harmful interference in a residential installation. This equipment generates, uses and can radiate radio frequency energy and, if not installed and used in accordance with the instructions, may cause harmful interference to radio communications. However, there is no guarantee that interference will not occur in a particular installation. If this equipment does cause harmful interference to radio or television reception, which can be determined by turning the equipment off and on, the user is encouraged to try to correct the interference by one or more of the following measures:

- Reorient or relocate the receiving antenna.
- Increase the separation between the equipment and receiver.
- Connect the equipment into an outlet on a circuit different from that to which the receiver is connected.
- Consult the dealer or an experienced radio/TV technician for help.

The Remote Control Battery

WARNING

To prevent possible **SERIOUS INJURY** or **DEATH**:

- NEVER allow small children near batteries.
- If battery is swallowed, immediately notify doctor.

To reduce risk of fire, explosion or chemical burn:

- Replace **ONLY** with 3V CR2032 coin batteries.
- **DO NOT** recharge, disassemble, heat above 212°F (100°C) or incinerate.

To replace the battery, pry open the case in the middle, then at each side with the visor clip. Insert replacement battery positive side up (+). Replace the batteries with only 3V CR2032 coin cell batteries. Dispose of old batteries properly.

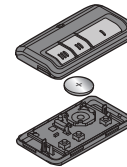

Caring for the LED Light Pods: Models WLED and WLED-267

The lighting of this garage door opener includes 100 premium LEDs. This provides an impressive daylight quality light and will illuminate all corners of the garage. With long lasting LEDs, you will not have to change light bulbs. If you do experience any issues with the LED, contact customer service or a certified door professional.

To remove dust or debris, carefully pull open the light pod and gently wipe out with a soft dry cloth.

Troubleshooting

Diagnostic Chart

Your garage door opener is programmed with self-diagnostic capabilities. The UP and DOWN arrows on the garage door opener flash the diagnostic codes.

DIAGNOSTIC CODE		SYMPTOM	SOLUTION
Up Arrow Flash (es)	Down Arrow Flash (es)		
1	1	The garage door opener will not close and the lights flash.	Safety reversing sensors are not installed, connected, or wires may be cut. Inspect sensor wires for a disconnected or cut wire.
1	2	The garage door opener will not close and the lights flash.	There is a short or reversed wire for the safety reversing sensors. Inspect safety sensor wire at all staple and connection points, replace wire or correct as needed.
1	3	The door control will not function.	The wires for the door control are shorted or the door control is faulty. Inspect door control wires at all staple and connection points, replace wire or correct as needed.
1	4	The garage door opener will not close and the lights flash.	Safety reversing sensors are misaligned or were momentarily obstructed. Realign both sensors to ensure both LEDs are steady and not flickering. Make sure nothing is hanging or mounted on the door that would interrupt the sensor's path while closing.
1	5	Door moves 6-8" (15-20 cm) stops or reverses.	Manually open and close the door. Check for binding or obstructions, such as a broken spring or door lock, correct as needed. Check wiring connections at travel module and at the logic board. Replace travel module if necessary.
		No movement, only a single click.	Manually open and close the door. Check for binding or obstructions, such as a broken spring or door lock, correct as needed. Replace logic board if necessary.
		Opener hums for 1-2 seconds no movement.	Manually open and close the door. Check for binding or obstructions, such as a broken spring or door lock, correct as needed. Replace motor if necessary.
1	6	Door coasts after it has come to a complete stop.	Program travel to coasting position or have door balanced by a trained door systems technician.
2	1-5	No movement, or sound.	Replace logic board.
3	2	Unable to set the travel or retain position.	Check travel module for proper assembly, replace if necessary.
3	3	The battery status LED is constantly flashing green.	Battery backup* charging circuit error, replace the logic board. * (If applicable.)

Troubleshooting

DIAGNOSTIC CODE		SYMPTOM	SOLUTION
Up Arrow Flash (es)	Down Arrow Flash (es)		
4	1-4	Door is moving stops or reverses.	Manually open and close the door. Check for binding or obstructions, such as a broken spring or door lock, correct as needed. If the door is binding or sticking contact a trained door systems technician. If door is not binding or sticking attempt to reprogram travel (refer to 29).
4	5	Opener runs approximately 6-8" (15-20 cm), stops and reverses.	Communication error to travel module. Check travel module connections, replace travel module if necessary.
4	6	The garage door opener will not close and the light bulbs flash.	Safety reversing sensors are misaligned or were momentarily obstructed. Realign both sensors to ensure both LEDs are steady and not flickering. Make sure nothing is hanging or mounted on the door that would interrupt the sensor's path while closing.

The garage door opener will NOT enter Wi-Fi LEARN mode:

- After the initial installation of the garage door opener, the garage door opener must complete a full cycle (open and closed) before the Wi-Fi LEARN mode can be activated.
- If there has been a recent power outage, the garage door opener must complete a full cycle before the Wi-Fi LEARN mode can be activated.

See 35 to activate Wi-Fi LEARN mode.

Cannot connect garage door opener to home Wi-Fi network:

- Ensure the myQ[®] Serial number was entered correctly and try again. The myQ[®] characters are between A-F and 0-9 only.
- Weak Wi-Fi signal in the garage. Ensure the Wi-Fi signal is reaching the garage, see 4 or visit LiftMaster.com/Customer-Support for more information.

My door will not close and the lights blink on my motor unit:

The safety reversing sensor must be connected and aligned correctly before the garage door opener will move in the down direction.

- Verify the safety reversing sensors are properly installed, aligned and free of any obstructions.

My garage door opener light(s) will not turn off when the door is open:

The garage door opener is equipped with a feature that turns the light on when the safety reversing sensors have been obstructed or when the motion sensor on the door control detects movement in the garage. This feature can be disabled using the door control, see page 38.

LEDs are not working (Models WLED and WLED-267 only):

Check wiring on both LED Pods to connector. If loose, then reconnect. If lights do not turn on, an LED driver board may be needed. Connect customer service or certified door professional to determine if a new LED driver board or LED array is needed.

My neighbor's remote control opens my garage door:

Erase the memory from your garage door opener and reprogram the remote control(s).

My vehicle's Homelink[®] is not programming to my garage door opener:

Depending on the make, model, and year of your vehicle an external adapter may be required. Visit www.homelink.com for additional information.

My camera won't connect to the router:

- Move your router closer to the garage door opener to minimize interference from walls and other objects.
- Buy a Wi-Fi range extender.

For issues with the camera, press and hold the reset button on the camera for 10 seconds. Then, follow the myQ[®] app instructions to set up the camera.

To troubleshoot the optional automatic garage door lock model 841LM, see the instructions provided with it.

Accessories

823LM



Remote Light Switch:

Replace an existing wall switch to control home lighting using your smartphone or garage door opener remote control. Smartphone control requires a connected myQ® account.

829LM



Door and Gate Monitor:

Monitor and close up to 4 myQ® enabled garage door openers or gate operators from any room in your home.

893MAX



3-Button MAX Remote Control:

Compatible with LiftMaster garage door openers manufactured since 1993. Includes visor clip.

880LMW



Smart Control Panel:

Displays temperature, time and system diagnostics; includes a push bar to open and close the door and a lock feature for extra security. Security+ 2.0 and Wi-Fi compatible.

825LM



Remote Light Control:

Plug into any interior lamp to control home lighting using your smartphone or garage door opener remote control. Smartphone control requires a connected myQ® account.

877MAX

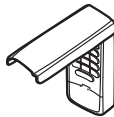

MAX Wireless Keyless Entry:

For use outside of the home to enable access to the garage using a 4-digit PIN. Works with ALL LiftMaster openers from 1993-present.

891LM



Single Button Remote Control:

Compatible with LiftMaster garage door openers manufactured since 1993. Includes visor clip.

882LMW



Multi-Function Control Panel:

Security+ 2.0 and Wi-Fi compatible.

975LM



Laser Garage Parking Assist:

Laser enables homeowners to precisely park vehicles in the garage.

819LMB



myQ® Home Bridge:

Add Apple® HomeKit™ compatibility to your myQ® enabled garage door opener. Use Siri® to open, close and check the status of your door.

Apple is a trademark of Apple Inc., registered in the U.S. and other countries. HomeKit is a trademark of Apple Inc.

374UT

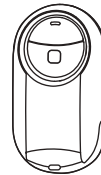

Mini Universal Remote Control:

The Mini Universal Remote Control can be programmed to activate up to two products, such as a garage door opener, myQ® light controls, gate operator, or commercial door operator.

375UT



Universal Remote Control:

The Universal Remote Control can be programmed to activate up to two products, such as a garage door opener, gate operator, or commercial door operator.

485LM



12V Battery for Backup System:

Provides backup power to the garage door opener.

841LM



Automatic Garage Door Lock:

Compatible with Security Shield garage door openers. Provides added security by automatically locking garage door travel at the garage door track.

881LMW



Motion Detecting Control Panel with Timer-to-Close Control:

Multi-function door control with motion sensor that automatically turns opener lights on when it detects a person entering the garage. Security+ 2.0 and Wi-Fi compatible.

886LMW



Motion Detecting Control Panel:

Multi-function door control with motion sensor that automatically turns opener lights on when it detects a person entering the garage. Security+ 2.0 and Wi-Fi compatible.

Warranty

LIFTMASTER® LIMITED WARRANTY

LiftMaster® (“Seller”) warrants to the first retail purchaser of this product, for the residence in which this product is originally installed, that it is free from defects in materials and/or workmanship for a specific period of time as defined below (the “Warranty Period”). The warranty period commences from the date of purchase.

WARRANTY PERIOD							
Models	Parts	Motor	Accessories	Belt	Battery Backup	LED Pods	Camera
8550W, 8550WL, 8550WLB, 8550WLB-267	5 years	Lifetime	1 year	Lifetime	1 year	N/A	N/A
85503 85503-267	5 years	Lifetime	1 year	Lifetime	1 year	N/A	1 year
8557W	5 years	Lifetime	1 year	Lifetime	N/A	N/A	N/A
WLED, WLED-267	5 years	Lifetime	1 year	Lifetime	1 year	5 years	N/A
8587W, 8587WL	5 years	Lifetime	1 year	N/A	N/A	N/A	N/A
8580WLB	5 years	Lifetime	1 year	N/A	1 year	N/A	N/A

The proper operation of this product is dependent on your compliance with the instructions regarding installation, operation, and maintenance and testing. Failure to comply strictly with those instructions will void this limited warranty in its entirety.

If, during the limited warranty period, this product appears to contain a defect covered by this limited warranty, call 1-800-528-9131, toll free, before dismantling this product. You will be advised of disassembly and shipping instructions when you call. Then send the product or component, pre-paid and insured, as directed to our service center for warranty repair. Please include a brief description of the problem and a dated proof-of-purchase receipt with any product returned for warranty repair. Products returned to Seller for warranty repair, which upon receipt by Seller are confirmed to be defective and covered by this limited warranty, will be repaired or replaced (at Seller’s sole option) at no cost to you and returned pre-paid. Defective parts will be repaired or replaced with new or factory-rebuilt parts at Seller’s sole option. [You are responsible for any costs incurred in removing and/or reinstalling the product or any component].

ALL IMPLIED WARRANTIES FOR THE PRODUCT, INCLUDING BUT NOT LIMITED TO ANY IMPLIED WARRANTIES OF MERCHANTABILITY AND FITNESS FOR A PARTICULAR PURPOSE, ARE LIMITED IN DURATION TO THE APPLICABLE LIMITED WARRANTY PERIOD SET FORTH ABOVE FOR THE RELATED COMPONENT(S), AND NO IMPLIED WARRANTIES WILL EXIST OR APPLY AFTER SUCH PERIOD. Some States and Provinces do not allow limitations on how long an implied warranty lasts, so the above limitation may not apply to you. THIS LIMITED WARRANTY DOES NOT COVER NON-DEFECT DAMAGE, DAMAGE CAUSED BY IMPROPER INSTALLATION, OPERATION OR CARE (INCLUDING, BUT NOT LIMITED TO ABUSE, MISUSE, FAILURE TO PROVIDE REASONABLE AND NECESSARY MAINTENANCE, UNAUTHORIZED REPAIRS OR ANY ALTERATIONS TO THIS PRODUCT), LABOR CHARGES FOR REINSTALLING A REPAIRED OR REPLACED UNIT, REPLACEMENT OF CONSUMABLE ITEMS (E.G., BATTERIES IN REMOTE CONTROL TRANSMITTERS AND LIGHT BULBS), OR UNITS INSTALLED FOR NON-RESIDENTIAL USE. THIS LIMITED WARRANTY DOES NOT COVER ANY PROBLEMS WITH, OR RELATING TO, THE GARAGE DOOR OR GARAGE DOOR HARDWARE, INCLUDING BUT NOT LIMITED TO THE DOOR SPRINGS, DOOR ROLLERS, DOOR ALIGNMENT OR HINGES. THIS LIMITED WARRANTY ALSO DOES NOT COVER ANY PROBLEMS CAUSED BY INTERFERENCE. UNDER NO CIRCUMSTANCES SHALL SELLER BE LIABLE FOR CONSEQUENTIAL, INCIDENTAL OR SPECIAL DAMAGES ARISING IN CONNECTION WITH USE, OR INABILITY TO USE, THIS PRODUCT. IN NO EVENT SHALL SELLER’S LIABILITY FOR BREACH OF WARRANTY, BREACH OF CONTRACT, NEGLIGENCE OR STRICT LIABILITY EXCEED THE COST OF THE PRODUCT COVERED HEREBY. NO PERSON IS AUTHORIZED TO ASSUME FOR US ANY OTHER LIABILITY IN CONNECTION WITH THE SALE OF THIS PRODUCT.

Some states and provinces do not allow the exclusion or limitation of consequential, incidental or special damages, so the above limitation or exclusion may not apply to you. This limited warranty gives you specific legal rights, and you may also have other rights, which vary from state to state and province to province.

Automatic Garage Door Opener Safety & Maintenance Guide

Garage Door Opener Safety – An Automatic Decision

A garage door is the largest moving object in the home. An improperly adjusted garage door and opener can exert deadly force when the door closes – which could lead to entrapment of children or adults and subsequent injury or death.

Proper installation, operation, maintenance, and testing of the garage door and automatic opener are necessary to provide a safe, trouble-free system. Careless operation or allowing children to play with or use garage door opener controls are also dangerous situations that can lead to tragic results. A few simple precautions can protect your family and friends from potential harm. Please review the safety and maintenance tips in this guide carefully and keep it for reference. Check the operation of your garage door and opener to ensure they function in a safe and trouble-free manner. Be sure to read all Important Safety Information found in your garage door opener's manual as it provides more details and safety considerations than can be supplied with this guide.

Garage Door Openers are Not Toys

Discuss garage door and opener safety with your children. Explain the danger of being trapped under the door.



Stay away from a moving door.



The wall-mounted push button should be out of reach of children, at least 5 feet from the nearest standing surface and away from all moving parts. Mount and use the button where you can clearly see the closing garage door.



Keep transmitters and remote controls out of reach of children. Do not let children play with or use transmitters or other remote control devices.



Keep the door in sight until it completely closes when using the wall-mounted push button or transmitter.

Routine Maintenance Can Prevent Tragedies

Make monthly inspection and testing of your garage door and opener system a part of your regular routine. Review your owner's manual for both the door and door opener. If you don't have the owner's manuals, contact the manufacturer(s) and request a copy for your specific model(s). Look for the opener model number on the back of the power unit.

⚠ WARNING – SPRINGS ARE UNDER HIGH TENSION. ONLY QUALIFIED INDIVIDUALS SHOULD ADJUST THEM.



Visually check the door and installation:

- Starting with the door in the closed position, use the manual disconnect on the opener to disconnect the door.
- Look for signs of wear or damage on hinges, rollers, springs, and door panels.
- These parts may require periodic lubrication. Check the owner's manual for suggested maintenance.
- If any signs of damage are evident, contact a trained door systems technician for assistance.
- Verify the photoeye height is no higher than 6" from the garage floor.

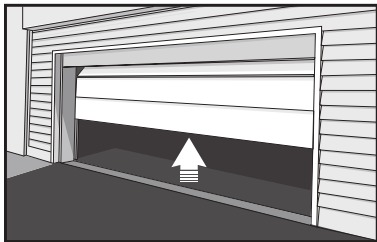

Test the door for proper operation:

- Open and close the door manually using handles or suitable gripping points.
- The door should move freely and without difficulty.
- **The door should balance and stay partially open 3–4 feet above the floor.**
- If you detect any signs of improper operation, contact a trained door systems technician for assistance.

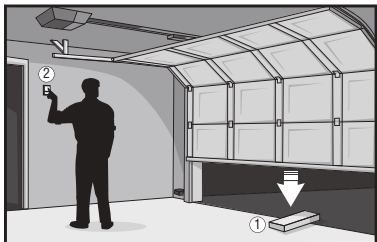

Test the opener safety features:

- Reconnect the opener to the door using the manual disconnect and open the door.
- Place a 2x4 board flat in the path of the door (1) and try to close it (2). The door should stop when it comes in contact with the 2x4 and then reverse direction.
- Block the photoelectric sensor by waving an object in front of the sensor and attempt to close the door. The door should not close unless the wall-mounted push button is manually held during operation.
- If the opener does not perform as described, contact a trained door systems technician for assistance.



Repair Parts

Models 8550W, 8550WL, 8550WLB, 8550WLB-267, 8557W, 85503 and 85503-267

RAIL ASSEMBLY PARTS

Description	Part Number
1 Belt - for 7 foot door Belt - for 8 foot door Belt - for 10 foot door	041A5434-11A 041A5434-13A 041A5434-14A
2 Belt Pulley Bracket	041B5424
3 Master link	004A1008
4 One-Piece Rail 7 feet (2.1 m) One-Piece Rail 8 feet (2.4 m) One-Piece Rail 10 feet (3 m)	G2777 G2778 G2770
5 Trolley Assembly Includes: Master Link (2), Clevis Pin (1), Ring (1), Belt Clip (1), Threaded Shaft (1), and Tensioner Assembly (1)	041B3869-3A
6 Tensioner Assembly	041B4103
7 Trolley Threaded Shaft	041A6689

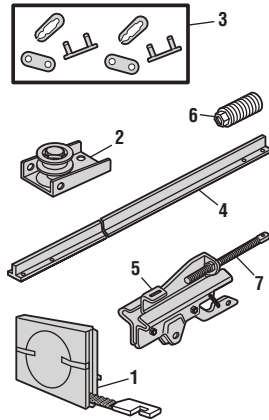

ACCESSORIES

Description	Part Number
1 Smart Control Panel®	880LMW
2 3-button remote control	893LM

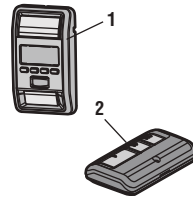

INSTALLATION PARTS

Description	Part Number
1 Curved door arm	041B0035B
2 Door bracket with clevis pin and fastener	041A5047-1
3 Emergency release rope and handle	041A2828
4 Header bracket with clevis pin and fastener	041A4353-1
5 Remote control visor clip	K029B0137
6 Safety sensor bracket	041A5266-3
7 Safety sensor kit with receiving and sending sensors with 3 feet (.9 m) 2-conductor wire	041A5034
8 Straight door arm	4178B0034B
9 White and red/white wire	041B4494-1
10 3V CR2032 lithium battery	K010A0020
11 Extension bracket (optional)	041A5281-1
Not Shown	
Installation hardware bag	041A2770-6
User's Guide	114A5216C

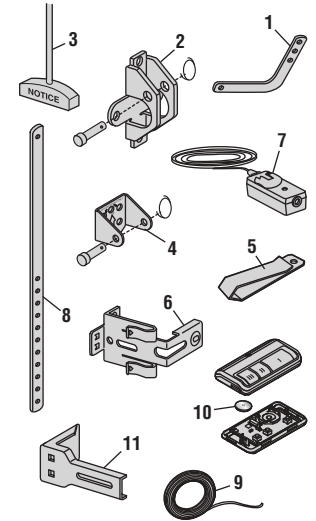

Repair Parts

Models 8550W, 8550WL, 8550WLB, 8550WLB-267, 85503, and 85503-267

GARAGE DOOR OPENER PARTS

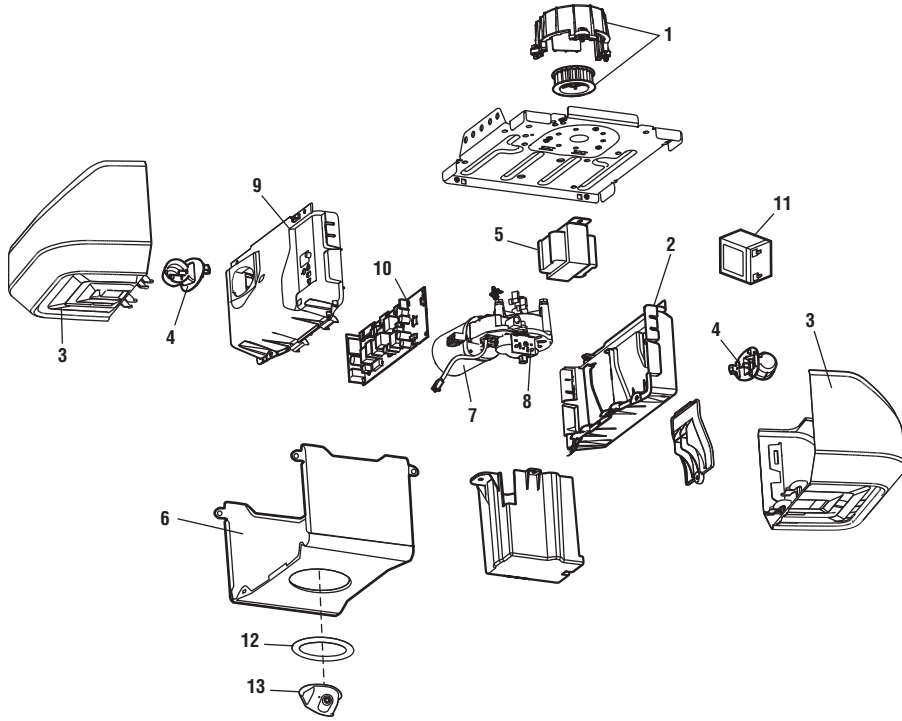

Description	Part Number
1 Sprocket and Sprocket Cover with Screws	041C589-2
2 End Panel with battery cover and light socket	041A7618
3 Light Lens	041A7562
4 Light socket	041C0279
5 Transformer	041D0277-1
6 Cover	
8550W	041D8257
8550WL 8550WLB 8550WLB-267	041D8859
85503 85503-267	041-0037
7 Motor with travel module	
8550WL 8550WLB 8550WLB-267	041D8006-1
85503 85503-267	041D1739-1
8 Travel Module	
8550WL 8550WLB 8550WLB-267	041D8071-4
85503 85503-267	041A7114-7
9 End Panel and light socket	
8550W	041D8198
8550WL 8550WLB 8550WLB-267 85503 85503-267	041D0216-2
10 Receiver Logic Board	
8550W 85503 85503-267	050DCTWF
8550WL 8550WLB 8550WLB-267	050DCTWFLK
11 Backup Battery	485LM
12 Decorative Cover - Models 85503 and 85503-267	041-0101
13 Camera - Models 85503 and 85503-267	041-0041
Not Shown	
Line cord	041B4245-1
Terminal block	041A3150
Wire Harness	
8550WL 8550WLB 8550WLB-267	041D9204
85503 85503-267	041-0042

Repair Parts

Model 8557W

GARAGE DOOR OPENER PARTS

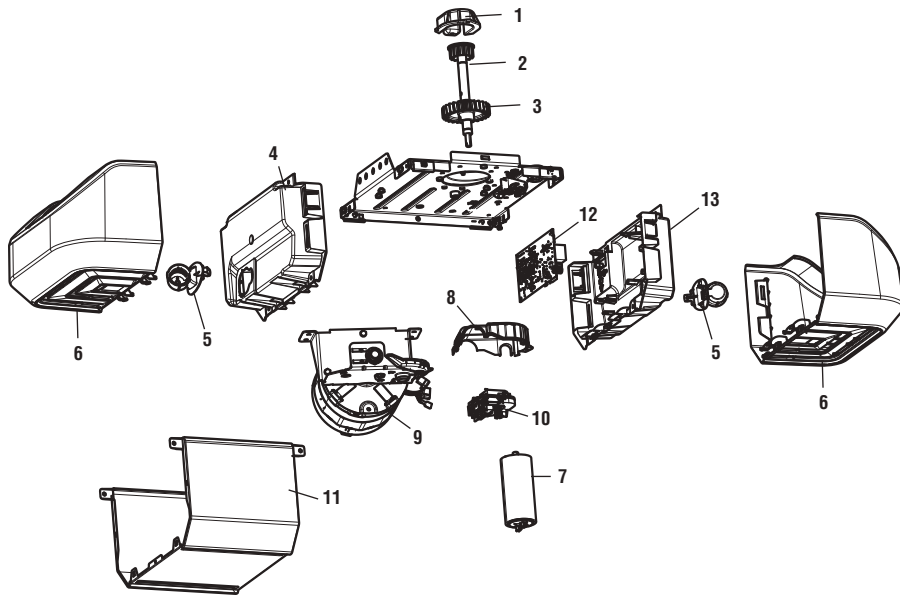

Description	Part Number
1 Sprocket cover	041A4371
2 Gear and sprocket	041A4885-5
3 Drive and Worm Gear	041A2817
4 End panel	041A7756-1
5 Light socket	041C0279
6 Light Lens	041A7562
7 Capacitor	030B0652
8 Gear Case	041A5532
9 Motor with Travel Module	041A7667
10 Travel Module	041D7742-5
11 Cover	041D8258
12 Logic board	050ACTWF
13 Logic Board End Panel	041D8198
Not Shown	
Line cord	041B4245-1
Terminal block	041A3150
Wire Harness	041D9204

Repair Parts

Models WLED and WLED-267

RAIL ASSEMBLY PARTS

Description	Part Number
1 Belt - for 7 foot door Belt - for 8 foot door Belt - for 10 foot door	041A5434-11A 041A5434-13A 041A5434-14A
2 Belt Pulley Bracket	041B5424
3 Master link	004A1008
4 One-Piece Rail 7 feet (2.1 m) One-Piece Rail 8 feet (2.4 m) One-Piece Rail 10 feet (3 m)	G2777 G2778 G2770
5 Trolley Assembly Includes: Master Link (2), Clevis Pin (1), Ring (1), Belt Clip (1), Threaded Shaft (1), and Tensioner Assembly (1)	041B3869-3A
6 Tensioner Assembly	041B4103
7 Trolley Threaded Shaft	041A6689

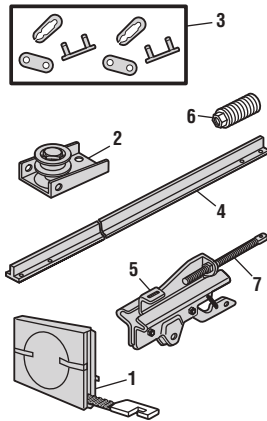

ACCESSORIES

Description	Part Number
1 Smart Control Panel®	880LMW
2 3-button remote control	893LM

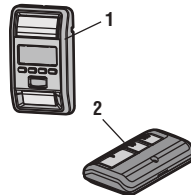

INSTALLATION PARTS

Description	Part Number
1 Curved door arm	041B0035B
2 Door bracket with clevis pin and fastener	041A5047-1
3 Emergency release rope and handle	041A2828
4 Header bracket with clevis pin and fastener	041A4353-1
5 Remote control visor clip	K029B0137
6 Safety sensor bracket	041A5266-3
7 Safety sensor kit with receiving and sending sensors with 3 feet (.9 m) 2-conductor wire	041A5034
8 Straight door arm	4178B0034B
9 White and red/white wire	041B4494-1
10 3V CR2032 lithium battery	K010A0020
11 Extension bracket (optional)	041A5281-1
Not Shown	
Installation hardware bag	041A2770-6
User's Guide	114A5227

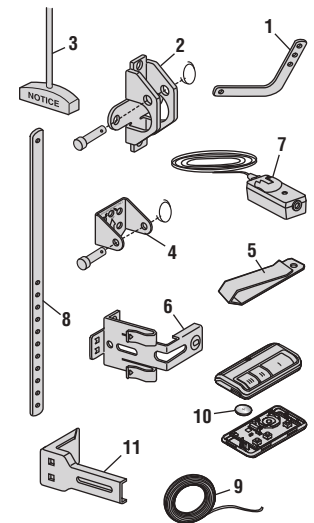

Repair Parts

Model WLED

GARAGE DOOR OPENER PARTS

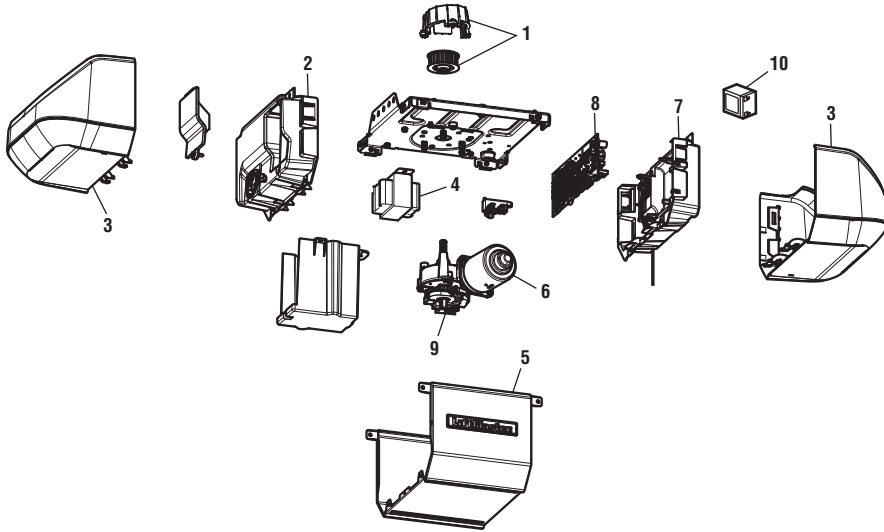

Description	Part Number
1 Sprocket and Sprocket Cover with Screws	041C0589-2
2 Front End Panel with LED Light Connector/Driver Board	041D9202
3 LED Light Pod	041D2052
4 Transformer	041D0277-1
5 Cover	041D8859
6 Motor with travel module	041D8006-1
7 End Panel for Receiver Logic Board with LED Light Connector	041D9276
8 Logic Board	050DCTWFLK
9 Travel Module	041D8071-4
10 Backup Battery	485LM
Not Shown	
Line cord	041B4245-1
Terminal block	041A3150
Wire Harness	041D9204

Repair Parts

Models 8587W, 8587WL, and 8580WLB

RAIL ASSEMBLY PARTS

Description	Part Number
1 Chain - for 7 foot door Chain - for 8 foot door Chain - for 10 foot door Chain - for 12 foot door Chain - for 14 foot door	041D3484 041D3483 041D3485 19-5812 19-5814
2 Chain Pulley Bracket	041A2780
3 Master link	004A1008
4 One-Piece Rail 7 feet (2.1 m) One-Piece Rail 8 feet (2.4 m) One-Piece Rail 10 feet (3 m) One-Piece Rail 12 feet (3 m) One-Piece Rail 14 feet (3 m)	3707CH 3708CH 3710CH 3712CH 3714CH
5 Trolley Assembly Includes: Threaded Shaft (1), Nuts (2), Washer (1), Clevis Pin (1), Ring (1), Master Link (1), Chain Extension	041A3489
6 Trolley Threaded Shaft	041A6689
Not Shown	
Rail Grease	K083A0011-1

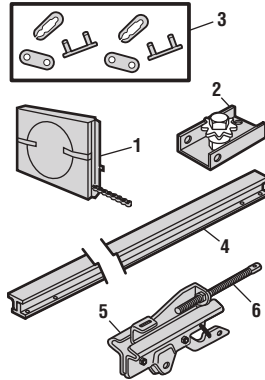

ACCESSORIES

Description	Part Number
1 Smart Control Panel®	880LMW
2 3-button remote control	893LM

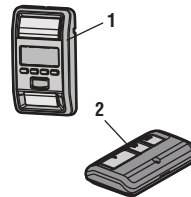

INSTALLATION PARTS

Description	Part Number
1 Curved door arm	041B0035B
2 Door bracket with clevis pin and fastener	041A5047
3 Emergency release rope and handle	041A2828
4 Header bracket with clevis pin and fastener	041A4353
5 Remote control visor clip	K029B0137
6 Safety sensor bracket	041A5266-3
7 Safety sensor kit with receiving and sending sensors with 3 feet (.9 m) 2- conductor wire	041A5034
8 Straight door arm	4178B0034B
9 White and red/white wire	041B4494-1
10 3V CR2032 lithium battery	K010A0020
11 Extension bracket (optional)	041A5281-1
Not Shown	
Installation hardware bag	041A2770-6
User's Guide	114A5216C

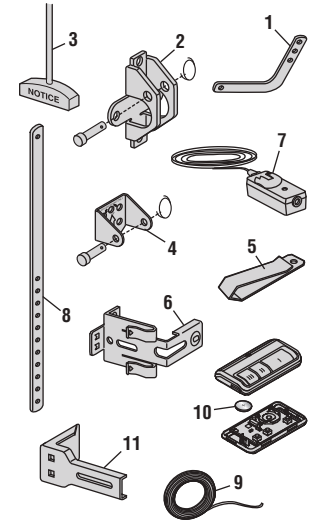

Repair Parts

Models 8587W and 8587WL

GARAGE DOOR OPENER PARTS

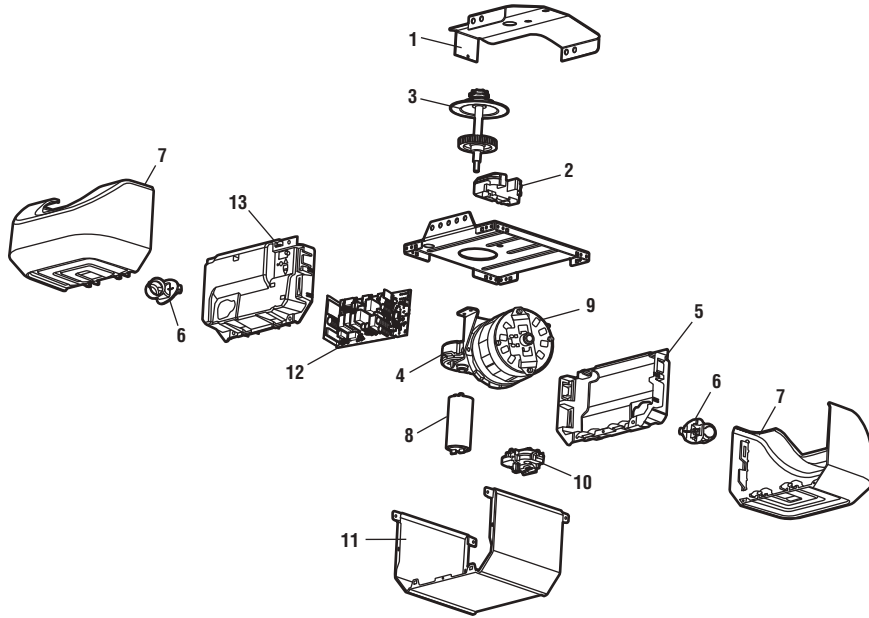

Description	Part Number
1 Chassis Support Bracket	041C5069
2 Chain spreader	041A4208-2
3 Gear and Sprocket	041A5658-1
4 Gear Case	041A5532
5 Front End Panel	041A7756-1
6 Light socket	041C0279
7 Light Lens	041A7562
8 Capacitor	030B0652
9 Motor with Travel Module	041A7767
10 Travel Module	041D7742-5
11 Cover	
8587W	041D8258
8587WL	041D8856
12 Receiver Logic Board	
8587W	041D8198
8587WL	050ACTWFLK
13 Logic Board End Panel	
8587W	050DCTWF
8587WL	041D0216-2
Not Shown	
Wire Harness	041A7814
Transformer	041A0308

Repair Parts

Model 8580WLB

GARAGE DOOR OPENER PARTS

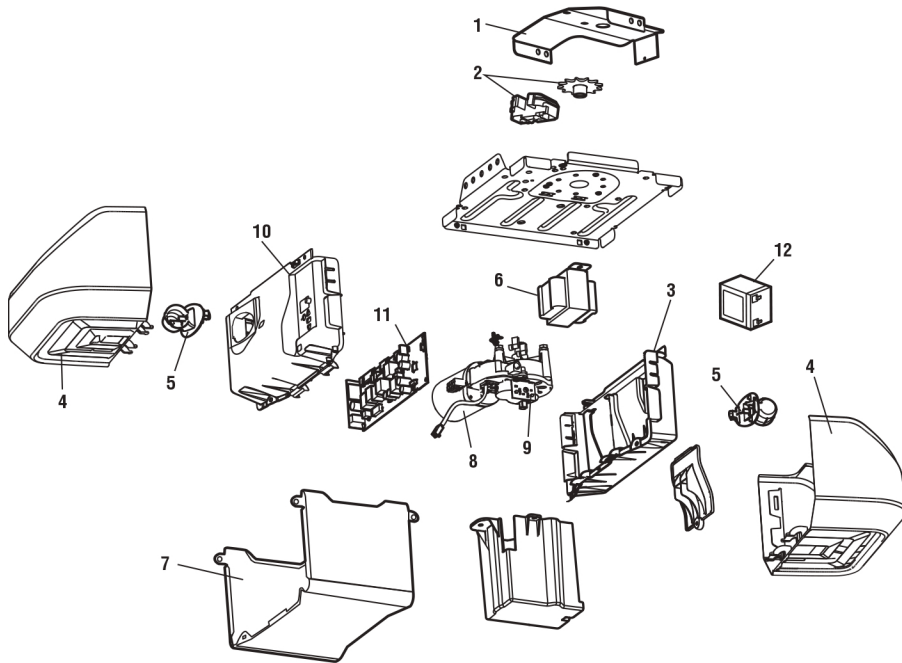

Description	Part Number
1 Chassis Support Bracket	041C5069
2 Chain spreader and sprocket	041-0035
3 End panel with battery cover and light socket	041A7618
4 Light Lens	041A7562
5 Light socket	041C0279
6 Transformer	041D0277-1
7 Cover	041D8859
8 Motor with travel module	041D8006-1
9 Travel Module	041D8071-4
10 End Panel and light socket	041D0216-2
11 Receiver Logic Board	041-0036
12 Battery Backup	485LM
Not Shown	
Wire Harness	041D9204
Line cord	041B4245-1
Terminal block	041A3150

Contact Information:

Use your part number, part name or model number to find the information you need.

For parts, go to:

LiftMaster.com/parts

For help and troubleshooting, go to:

support.chamberlaingroup.com